



HAL
open science

Geological Storage of CO₂: a State-Of-The-Art of Injection Processes and Technologies

B. Cailly, P. Le Thiez, P. Egermann, A. Audibert, S. Vidal-Gilbert, X. Longaygue

► **To cite this version:**

B. Cailly, P. Le Thiez, P. Egermann, A. Audibert, S. Vidal-Gilbert, et al.. Geological Storage of CO₂: a State-Of-The-Art of Injection Processes and Technologies. Oil & Gas Science and Technology - Revue d'IFP Energies nouvelles, 2005, 60 (3), pp.517-525. 10.2516/ogst:2005034 . hal-02017213

HAL Id: hal-02017213

<https://ifp.hal.science/hal-02017213>

Submitted on 13 Feb 2019

HAL is a multi-disciplinary open access archive for the deposit and dissemination of scientific research documents, whether they are published or not. The documents may come from teaching and research institutions in France or abroad, or from public or private research centers.

L'archive ouverte pluridisciplinaire **HAL**, est destinée au dépôt et à la diffusion de documents scientifiques de niveau recherche, publiés ou non, émanant des établissements d'enseignement et de recherche français ou étrangers, des laboratoires publics ou privés.

Geological Storage of CO₂: A State-of-the-Art of Injection Processes and Technologies

B. Cailly¹, P. Le Thiez¹, P. Egermann¹, A. Audibert¹, S. Vidal-Gilbert¹ and X. Longaygue¹

¹ Institut français du pétrole, 1 et 4, avenue de Bois-Préau, 92852 Rueil-Malmaison Cedex - France
e-mail: blandine.cailly@ifp.fr - pierre.le-thiez@ifp.fr - patrick.egermann@ifp.fr - annie.audibert@ifp.fr
sandrine.gilbert@ifp.fr - xavier.longaygue@ifp.fr

Résumé — Stockage géologique du CO₂ : état de l'art des technologies d'injection — Dans cet article, les technologies de puits nécessaires à l'injection de CO₂ sont présentées ainsi que les mécanismes physico-chimiques provoqués par l'injection autour du puits :

- Les matériaux utilisés pour le puits et les procédures d'abandon de puits doivent être choisis de façon à éviter toute fuite de CO₂ le long du puits et d'assurer la sécurité à long terme du stockage.
- La zone autour du puits subit des mécanismes de dissolution/reprécipitation causés par l'injection de CO₂, qui peuvent influencer sur l'injectivité. Ces phénomènes dépendent fortement des caractéristiques du réservoir et requièrent aujourd'hui une étude théorique et expérimentale approfondie afin de contrôler l'injectivité des puits d'injection de CO₂, élément clé car de grandes quantités de CO₂ devront être injectées.

Abstract — Geological Storage of CO₂: A State-of-the-Art of Injection Processes and Technologies — An overview is given of the well technology needed for CO₂ injection and the near wellbore processes:

- Well materials and abandonment procedures must be designed in order to avoid CO₂ leakage through the well to ensure long-term safety of the CO₂ storage. Furthermore, various mechanical effects can affect the well and the injection process. Geomechanical models are required to identify the optimal injection pressure that will damage neither the well nor the reservoir.
- The near wellbore region is subjected to chemical phenomena due to CO₂ injection which may affect drastically the injectivity. These dissolution/reprecipitation mechanisms are very case-dependant and need more theoretical and experimental investigation in order to control the injectivity of a CO₂ injection well, which is crucial because huge amounts of CO₂ will have to be injected.

INTRODUCTION

Injection of fluids into reservoir rocks is a well known technology in oil and gas industry specially for a better hydrocarbons recovery and it can be considered that many of the technologies required for CO₂ geological storage already exist. Drilling and completion technologies are now able to deal with both vertical and horizontal wells in deep formations, with multiple completions and in specific well-defined cases able to handle acid fluids.

When a CO₂ injection well is considered, the following issues need to be addressed:

- CO₂ is a reactive component, when dissolved in water it may cause some corrosion to the injection well materials and can also change the reservoir properties in the near wellbore region.
- Injection rates may be very high, which can also have a mechanical impact on wells and on near wellbore structures.
- CO₂ will be stored for a long period of time (> 1000 years): this imposes a lot of requirements for the well design and specific procedures for its abandonment.

This paper is divided into two parts. The first part addresses the issues related to well technologies and abandonment procedures. The second one is focused on injectivity, which is very sensitive to the evolution of the reservoir near wellbore properties consecutively to the CO₂ injection.

1 WELL TECHNOLOGY

1.1 Well Design

The overall design of a CO₂ injection well is not fundamentally different compared to what is implemented in a water injection well (major differences will concern the wellhead valves and flanges that need to be upgraded for higher pressures and corrosion). The technology for handling CO₂ has already been developed for EOR operations and for the disposal of acid gas (H₂S/CO₂ mixtures).

For CO₂ injection through existing and old wells the key factors will be:

- wellbore integrity;
- mechanical state of the well;
- quality of the cement used for the initial well completion;
- well maintenance.

In case of leakage through well-bore annulus, CO₂ can migrate into unwanted zones such as adjacent reservoir zone and aquifers, with the risk of contamination of those aquifers, economic loss, reduction of CO₂ flood efficiency and storage efficiency. Commonly, a detailed logging program for checking well-bore integrity is conducted by the operator to protect aquifers and prevent reservoir cross-flow. A well used for injection must be equipped with a packer to isolate

pressure within the injection interval. All materials used in the injection well should be designed to anticipate peak volume, pressure, and temperature. Because of corrosion problems, tubing, casing, valves, etc must be made of a CO₂ compatible material.

Injection wells are commonly equipped with two valves (gate or ball valves) for well control: an outside valve for regular use and an inside valve for safety. In acid gas injection wells, a downhole safety valve is incorporated in the tubing so that in case of surface equipment failure, the well is automatically shut down. The valves are made of special type of stainless steel or aluminium bronze. In his monograph on practical aspects of CO₂ flooding, Jarrell *et al.* (2002) [1] recommend a positive shutoff on all CO₂ wells to ensure that no release occurs and to prevent CO₂ from inadvertently flowing back into the injection system. Seals that are always contained and not exposed to the atmosphere during routine operations work well. For those regularly exposed to the atmosphere, such as the seal on the line blind and the top bonnet seal of the simplex orifice fitting, Jarrell *et al.* (2002) [1] recommend Teflon which does not absorb CO₂ and is less likely to fail. A typical downhole configuration for an injection well includes a double-grip packer, an on-off tool with a profile nipple, and a downhole shutoff valve. The optimal tubing type and size should be determined on a lease-by-lease basis because several options have proved effectiveness. The most widely used kind of tubing for water-alternating-gas (WAG) injection includes bare carbon steel, plastic-coated steel, fibre-glass-lined steel, and cement-lined steel. Annular pressure monitors help to detect leaks in packers and tubing, which is important for taking quick corrective actions. To prevent dangerous high pressure build-up on surface equipment, CO₂ injection must be stopped as soon as leaks occur. Rupture disks and pop-off valves can be used to relieve build-up pressure.

1.2 Material Deterioration Risks

Material selection for CO₂ injection well is critical in order to reduce the costs of underground disposal of CO₂. Moreover, this choice should take into account deterioration risks related to CO₂ injection and long-term storage in the reservoir, so as to avoid CO₂ leakage along the well. This section addresses problems related to steels and cements.

1.2.1 Steels

CO₂ Corrosion on Steels

Carbon dioxide (CO₂), like hydrogen sulphide (H₂S), is a weak acid gas and becomes corrosive when dissolved into water. The process of aqueous CO₂ corrosion and the corrosion rate on steels are well known. The factors determining the rate of corrosion are the temperature and CO₂ partial pressure. Velocity effects are very important, corrosion rates on carbon steels can reach very high levels:

25 mm/y (1000 mils/y) at 65°C and 1 MPa CO₂ pressure, and 250 mm/y (10 000 mils/y) at 82°C and 16 MPa CO₂ pressure. Gaseous or supercritical dry CO₂ is not corrosive [2, 3].

Different forms of corrosion can occur on contact with CO₂ acid water:

- *General corrosion* refers to corrosion dominated by uniform dissolution and thinning. Carbon steels undergo this form of corrosion when in contact with CO₂ acid water. The CO₂ corrosion rate on carbon steels has been largely studied in the past and numerical models taking into account temperature and CO₂ partial pressure can predict it. Design overthickness and injection of corrosion inhibitors are the basic means to prevent this kind of corrosion. The best way is to use corrosion-resistant alloys, but these materials are very expensive compared to carbon steels.
- *Localised corrosion* happens when the corrosion damage produced is localised rather than uniformly spread over the exposed metal surface, making this form of attack more difficult to deal with. The forms of localised corrosion are mainly pitting and crevice formation, but crevices are mostly met in presence of H₂S rather than of CO₂. Pitting is one of the most insidious forms of corrosion, since pits are generally small and are not easy to detect. It can cause failure by perforation although very little weight loss has occurred. The most common cause of pitting corrosion on corrosion-resistant alloys is contact with chlorides. Carbon steels are less sensitive to chlorides than alloys.

Steel Selection Criteria

Traditionally, carbon and low-alloy steels were virtually the only metals used in the production of hydrocarbons, because they are relatively cheap and show no insurmountable corrosion problems. When oil prices increased and deeper wells were drilled encountering more severe corrosive environments, corrosion-resistant alloys were developed. However, at the present time, most of the wells in place in hydrocarbon fields are built with carbon steels [2].

For cost reasons, CO₂ injection in depleted reservoirs will probably reuse wells already in place drilled for production, if it is acceptable for safety reasons. According to experience from the use of CO₂ injection for enhanced oil recovery (EOR), which is a well-known technology, it is accepted that carbon steel can be used in presence of dry CO₂. But if it is wet, corrosion-resistant-alloys are required.

CO₂ Injection and Corrosion Risks

If CO₂ is injected in a dry supercritical state, there is no important risk of corrosion, because the corrosion rate of metals in presence of dry supercritical CO₂ is very low. In that case, carbon steel is sufficient during this phase, sometimes with the help of corrosion inhibitors.

After the injection period, during the long-term storage phase, the supercritical CO₂ can be hydrated with water contained in the reservoir and wet CO₂ or acid brine can reach the well. Then acidic water phase can degrade the

cement protecting the steel casing. The effects of the degradation products from cement on steel can be severe, and are yet ignored. The problem is that the exact state of the CO₂ rich phase after injection is not precisely known, and that the corrosion process of aqueous supercritical CO₂ has not been characterised until now.

The properties of CO₂ over a representative range of pressures and temperatures and corrosion rates for aqueous supercritical CO₂ should be defined by laboratory testing. Modelling thermodynamic studies are needed to define long term equilibrium conditions, in order to avoid failures after injection. The presence of corrosive fluids initially present in the reservoir must also be taken into consideration.

According to the work of the *Institute for Energy Technology* in Norway supported by *Statoil* [4], wet CO₂ corrosion rates on carbon steel at high pressure are far smaller than expected from models developed at low pressure. Meanwhile, further investigations are needed to understand this phenomenon, which could be partially explained by the formation of protective carbonate films on the surface of the steel.

Sleipner Vest CO₂ Storage [5]

This project differs from future industry practice (capture of CO₂ in flue gas) in that the CO₂ is wet and contains methane. Assessment of the fluid corrosivity concluded that the water in place would produce an acidic water film by wetting the metal surfaces. In order to provide the necessary confidence in the long-term service required, a corrosion resistant alloy (annealed 25% Cr duplex stainless steel) has been chosen for the tubular and the exposed parts of the casing. However this expensive materials choice is probably due to the global technical stake of the project and it cannot be considered as representative of a common practice for further developments of that kind.

1.2.2 Cement

The well must be hydraulically isolated by a cement annulus in order to ensure the wellbore and formations integrity during the injection and the long-term storage.

Deterioration on Cement

Cement is threatened in acidic environment. Two types of deterioration on cement caused by CO₂ injection must be considered:

- *Mechanical deterioration*, during the injection and after the injection. For instance, geochemical deposits in the cement pores can generate stresses that in turn can induce cracks.
- *Chemical deterioration* on the contact of cement and casing and of cement and geological formation:
 - Carbonic acid leaching can degrade cement. The variation of the chemical composition of the pore solution can induce interactions with cement minerals. This variation depends on the exchanges between the

interstitial solution with the external environment. It has been observed during CO₂ EOR experiments that well cement after long-term exposure to carbonic acid leaching could be deteriorated with loss of compressive strength and structural integrity. This process, known as cement carbonation, is intensified by high temperature (>180°C). The carbonic acid and the carbon dioxide react with the calcium hydroxide and the calcium silicate hydrate gel from the cement inside the pores, forming calcium carbonate and calcium bicarbonate migrating out of the cement. Cement carbonation increases porosity and permeability and decreases compressive strength [6].

- Furthermore, the CO₂ injected in excess forms a high concentrated gas bubble with very high solvent capacity. The bubble can bring back to the well water, hydrocarbons, and any product that comes across in the reservoir. These products can alter the cement.

The precise effects of CO₂ injection on cement must be defined by experiments and modelling. The reservoir fluids, temperature and stress conditions must be taken into account. These studies are needed to identify the more resistant cement compositions for CO₂ acidic downhole environments.

Use of Existing Wells for CO₂ Injection in Depleted Reservoirs

Most of the cement annulus of the hydrocarbon production wells encounters failures because of the stresses evolution during production. The gas-tightness of the cement annulus must be controlled before reusing wells for CO₂ injection.

Monitoring

Continuous pressure monitoring of the annular fluid is needed in order to identify and repair any failure before that CO₂ leakage induces any damage [7].

Well Closure

After injection, specific designs should be considered to close the well with successive cement seals alternately with special materials like compacted shales.

1.2.3 Interactions between Steel and Cement Deterioration

A lot of studies have been carried out on “bulk-corrosion” of materials like cements and steels. Another important problem has to be addressed: the role, behaviour and evolution of interfaces between reservoir rock and cement on one hand, and between cement and casing on the other hand (*Fig. 1*). It is suspected that degradation of these interfaces due to chemical alterations and to mechanical constraints during the life-cycle of the well (injection/reservoir compression, abandonment, etc.) can lead to CO₂ migration pathways. In that case, risks of leakage through these mechanisms could be much higher than those expected through bulk alteration of cement or steel.

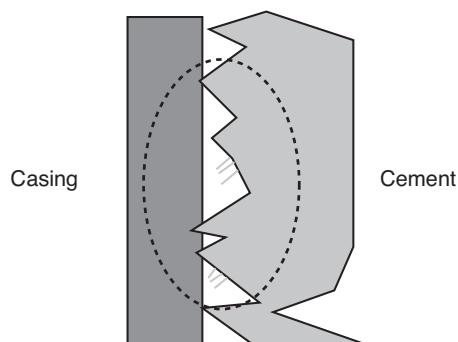

Figure 1
Interface between cement and casing.

It is very important to take into account interactions between degradation products of cement and interface with steel, and degradation products of steel with cement and interface. The effects of the degradation products from cement on steel can be severe, and are yet ignored.

Modification of stresses on the well materials and on the near-wellbore during the lifecycle of the well due to pressure changes (increases and decreases) can also lead to loss of adherence between cement and casing.

1.2.4 Conclusion

As far as the CO₂ injected is dry, there is a limited risk of degradation during the injection phase (however, cement contains water). But once in the reservoir, the CO₂ can become hydrated, and the resulting acidic water could product severe deterioration of the materials that are not easy to handle with and that could be complicated by poorly known (and complex) local conditions (temperature, pressure, composition, nature of phases). Experiments in simulated representative environmental media and modelling are needed to characterise deterioration on well materials caused by long-term CO₂ storage. Reservoir conditions (fluids and minerals, temperature, pressure) must also be taken into account. Interactions between degradation products and well materials must not be neglected.

1.3 Well and Reservoir Constraints During Injection

A key to the success of long-term CO₂ storage in depleted oil or gas fields as well as in deep saline aquifers is the hydraulic integrity of both the geological formations that bound the reservoir and the wellbores that penetrate it. However, various mechanical and chemical effects, either during CO₂ injection or during the subsequent CO₂ storage period affect the reservoir rock. During injection, the mechanical impact depends on critical parameters including the upper and lower bounds of pressure and temperature experienced by the reservoir, the orientation and mechanical properties of

existing faults, rock mechanical properties, *in situ* stresses, reservoir depth and shape [8, 9].

1.3.1 Stresses Effects

During injection, the pore pressure increase induces reservoir expansion. This phenomenon can result in shear stresses at the reservoir and cap-rock boundary. For anticline reservoirs, large horizontal compressive stresses can develop at the apex of the structure. In order to avoid this deformation, a preliminary geomechanical study is required to identify the maximum allowable pressure increase in the dome and the related injection parameters.

1.3.2 Pore Pressure Effects

There are a number of mechanisms that can result in the reactivation of existing faults during injection. Local pressure increase in a fault plane during injection may reactive faults within reservoir or bounding the reservoir. In that case, the pore pressure change is localised in the vicinity of a fault. Moreover, pore pressure changes throughout the reservoir cause an *in situ* stress variation. The fault reactivation induced by *in situ* stresses changes is affected by factors such as the thickness, lateral extend and shape of the reservoir, the mechanical properties of the reservoir and the surrounding formations, and the presence, orientation and strength of existing faults within or around the reservoir. Geomechanical analysis are needed in order to locate injection wells as far as

possible from faults, and to determine their behaviour at reservoir pressures induced by CO₂ injection.

1.3.3 Hydraulic Fracturing

High injection pressures combined with low injection fluid temperatures can induce hydraulic fracturing which can affect the bounding seals (cap-rock, overburden). The best way to avoid hydraulic fracturing would be to determine the maximum injection pressure that the reservoir can bear. Injection wells should intersect the highest permeability zones of the reservoir. Moreover, horizontal wells would be a very interesting solution.

Geomechanical analysis and models are required to identify the maximal injection pressure that will not induce fractures in the reservoir and to characterise *in situ* stresses and faults, and fault reactivation hazard. The availability of geomechanical data from sequestration site, the integration of chemical and geomechanical processes that can modify the mechanical properties of rocks and monitoring of induced microseismicity are key issues for better geomechanical analysis.

1.4 Well Abandonment Requirements

Procedures are required concerning the well closure, in order to avoid CO₂ migration through the caprock along the well during the long-term storage phase [7]. Figure 2 shows

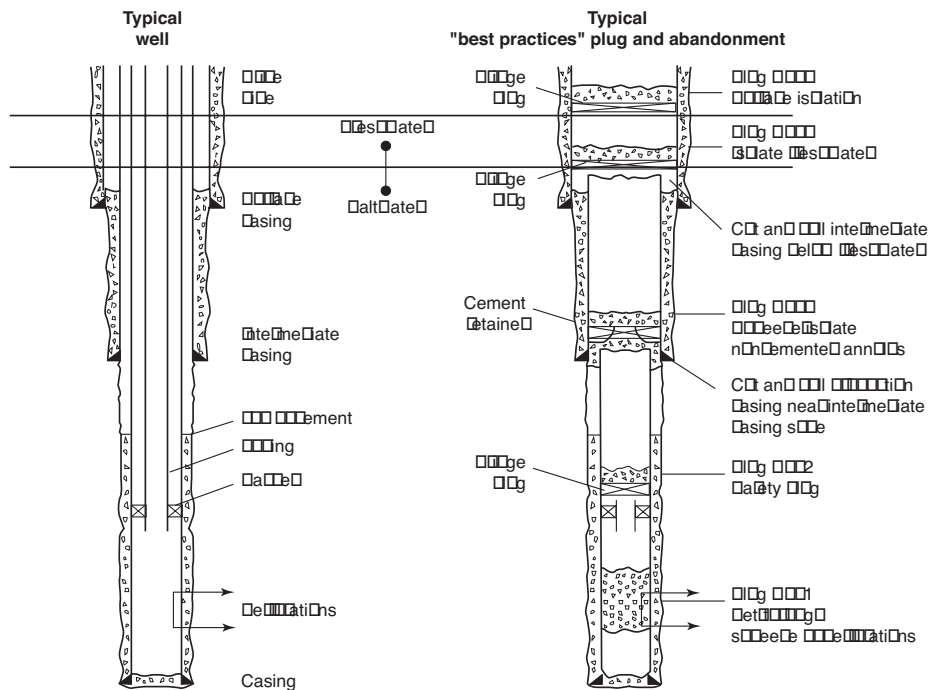

Figure 2
Typical injection well and abandoned well.

typical configuration for the abandonment of a typical well. Any other wells, old or new, like producers have also to be considered, as potential pathways for CO₂ migration.

1.4.1 Well Sealing

The injection zone, hydrocarbon and potable water bearing zones must be hydraulically isolated by cemented casing. After cement squeezing which will close the micro-fractures around the wellbore, multiple cement plugs should be set up in the well, alternating with pressure barriers (for instance, compacted shales). These materials should be chemically inert. A last cement plug must be put at the surface after the wellhead removal. The well should be filled with a non-corrosive completion fluid.

1.4.2 Material Selection

The materials penetrating the caprock and the reservoir (liner, casing, tubulars, etc.) must be chosen in order to avoid any failure provoking CO₂ leakage (steel corrosion, cement deterioration) during the sequestration. See item Section 1.2.

1.4.3 Moving the CO₂ Away from the Injection Wells

CO₂ dissolved in water can deteriorate the well materials. Moving the CO₂ away from the injection wells if it is possible is a good way to protect the well.

If the reservoir is an anticline, injection wells should be located on the flanks: the CO₂ will migrate on the dome of the structure, away from the wells.

Fluids can be injected in the reservoir after the end of the CO₂ injection to displace the gas bubble.

1.4.4 Modelling of the Long-Term CO₂ Migration along Abandoned Wells from Weyburn [10]

Stochastic modelling of leakage along abandoned wells from Weyburn data gives encouraging results. This study underlines the importance of the cement seal quality, which permeability must be very low. According to this work, the maximum possible leakage by 5000 y is 0.14% of the initial CO₂ for the Weyburn system, with more than 800 wells, as far as the cement degradation is regularly treated.

2 NEAR-WELLBORE PROCESSES DURING CO₂ INJECTION

Several coupled physical and chemical processes may occur during the injection depending on time and location within the reservoir. Far field regions are facing long term reaction in a situation where flow of gas and water at a reduced rate may induce near fluid-rock equilibrium. In contrast, near wellbore regions are subjected mainly to gas at a high flow rate where dissolution/reprecipitation phenomena may drastically increase/decrease the injectivity.

CO₂ is not an inert gas like natural gas: it interacts with rock minerals of the reservoir matrix. The injection phase is characterised by complex polyphasic flows in the reservoir. Dynamical instabilities act on CO₂ dissolution process. Figure 3 describes the both fluid-rock and fluid-fluid interactions that may affect the CO₂ injectivity.

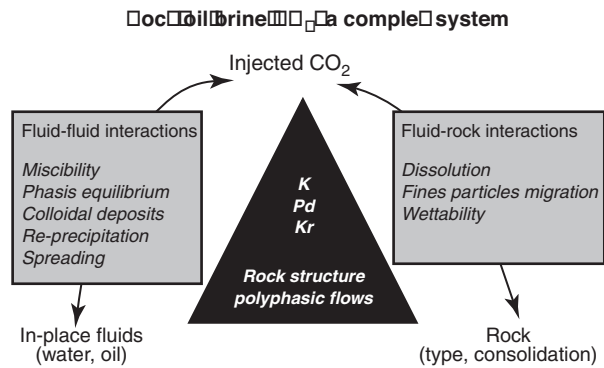

Figure 3

Interactions between the injected CO₂ and the reservoir (IFP).

2.1 Geochemical Processes in the Reservoir Induced by CO₂ Injection

CO₂ injection can alter mechanical properties of the reservoir rock by inducing chemical reactions (dissolution and precipitation of minerals), in particular CO₂ precipitation in calcite. The kinetic of this reaction is very fast and helped by the injection flow. Calcite precipitation can threaten the injection by cementing the reservoir around the well. The related dissolution of the matrix provokes a risk of subsidence and fracture. The effective elastic properties of the reservoir rock are affected during CO₂ injection phase and rock will behave like non-linear material. Numerical models are used to simulate geomechanical effects triggered by chemical interactions between CO₂ and reservoir rocks. The rock mechanical parameters estimated for different alteration degrees are then used to perform non-linear elastic modelling. Geochemical processes depend on the matrix composition, composition of the fluids in place, temperature and fluids pressure.

Carbonates are the first minerals to be dissolved (anorthites, dolomites, oligoclases). These dissolutions occur very fast, as soon as the injection starts. The precipitation of carbonated minerals following these dissolutions is called CO₂ mineralogic trapping. It represents a mineralogic way of CO₂ storage that lasts for centuries (calcite will dissolve about 1000 y after precipitating) [11]. But it threatens the injectivity by cementing the matrix.

2.2 Background on Dissolution/Precipitation Mechanisms in Carbonates

CO₂ dissolves in water forming carbonic acid, H₂CO₃, which then dissociates to give an acid that reacts with the calcite present as carbonate. The chemical reactions are as following:

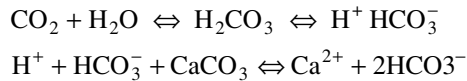

This set of reaction clearly indicates that acid is formed by contact of CO₂ with water. As long as the CO₂ gas is injected and it is in contact with the water phase, acid will be formed. In this situation, acid concentration is “unlimited”: even though acid is spent by reaction, complete spending will never occur and there is in the system an almost unlimited source of acidity.

At this step, it is important to note that the dissolution potential of the system with two phases, *i.e.* a water phase and a CO₂ phase, flowing simultaneously is very different from the situation where a water phase, saturated in CO₂, is the only mobile phase. In the first case, as seen before, the dissolution potential is unlimited whereas in the second case, the acidity is removed progressively as the dissolution proceeds. Studies dealing with the injection of water saturated with CO₂ are investigating only one face of the problem.

Bazin and co-workers [12, 13] have conducted acidizing experiments using both limestone and dolomite and acid fluids with a wide concentration range. Acid dissolution of carbonates is controlled by acid mass transfer kinetics and is highly flow rate dependent. This coupling of transport and reaction is a characteristic of carbonate dissolution. It is an unstable dissolution process leading to different dissolution regimes, with the so-called wormhole pattern being the most characteristic. Dissolution figures are controlled by the acid injection flow rate. Three dissolution regimes have been identified. At very low flowrate, the acid is locally spent and the dissolution figure is compact. When the flow rate increases, acid is not completely spent locally and remaining acidity is transported farther. The dissolution regime is called the wormholing regime. At very high flow rate, the high acid filtration from the wormhole walls makes the dissolution figure very ramified. The dissolution pattern is named “ramified wormhole” or uniform dissolution.

Reactive transport phenomena during CO₂ injection have been studied both on sandstones [14] and carbonates [15, 16]. The experimental results showed that either permeability improvement or permeability impairment can be obtained [17]. These results demonstrate that the injectivity issue during CO₂ injection is very case dependent because it is related to the rock fabric, the brine composition and also the thermodynamic conditions. Therefore, it is of primary importance to work under representative conditions (fluids, rock and pressure/temperature) in order to derive relevant

recommendations for field applications. Available experimental data sets have been obtained through either carbonated brine injection or co-injection of CO₂ and brine. Dissolution patterns have been observed in most of these experiments and also on the field [18]. Surprisingly, little attention has been paid to date on the influence of the hydrodynamic regime on these mechanisms in spite this is a key parameter in the near wellbore region where the fluid velocity varies a lot over a short distance [19]. This coupling between transport and reaction is prone to generate specific porosity/permeability relationships according to the flow regime. These relations are very important to introduce in numerical model in order to reproduce properly the pressure field around the well and the stress variations that can be detrimental for the wellbore integrity.

2.3 IFP Works on Dissolution/Precipitation Mechanisms in Carbonates During CO₂ Injection

As part of a laboratory investigation of CO₂ sequestration in carbonate reservoir, the qualitative consequences of dissolution/precipitation mechanisms in carbonates during CO₂ injection on the extent of permeability variations have been studied [20]. The various situations in representative reservoir conditions with the objective of achieving knowledge and data for future physical and numerical modelling and reservoir numerical simulations of CO₂ injection have been experimentally investigated. Experiments have consisted in the co-injection of supercritical CO₂ and brine in carbonate cores (limestone).

2.3.1 Importance of the Multiphase Flow

Some experimental observations like the abnormal pressure drop response obtained under high injection rate strongly suggest that solid particles displacements can occur. This phenomena can lead to severe permeability impairment and is certainly activated both by the weakening of the pore structure consecutively to the dissolution process and also by the simultaneous flow of CO₂ and brine, which contributes to generate higher pressure drop for a given flow rate.

The simultaneous flow of CO₂ and brine is also important to consider because it limits the access of the reactive brine to a limited fraction of the pore space due to the non wettability of the CO₂ phase. Therefore it impacts a lot the way the pore structure is modified by dissolution or precipitation and the associated permeability evolutions.

2.3.2 Implications for the Well Injectivity

The results of this experimental study demonstrate that the injectivity issue is very complex because it results from a combination between many parameters (the rock fabric, the fluid compositions, the thermodynamic conditions, the flow regime). The analysis of the experimental data have

confirmed that both precipitation and dissolution can take place in the core during a given experiment leading to opposite effects on the permeability evolution. It is interesting to mention that high rates tend to limit the permeability reduction due to precipitation because the residence of the fluids is shorter in this case. It makes the system being far from the geochemical equilibrium leading to lower amount of precipitated calcium sulfate. From a practical point of view, it suggests that severe permeability impairment in the near wellbore can be avoided in spite of unfavourable geochemical conditions if the injection rate is high enough to displace the equilibrium area of precipitation far from the well.

These results also demonstrate that the pore structure evolution is very dependent on the flow regime. Therefore, a specific porosity/permeability relationship has to be introduced in the numerical model as a function of the flow regime to get relevant results. This is particularly important to properly reproduce the pressure field around the well, where the flow rate varies a lot and can induce severe stress variations that can be detrimental for the wellbore integrity.

2.4 Injectivity Problems Reported in Field Operations During CO₂/Acid Injection

IFP and Total have investigated injectivity and near-wellbore damage that have been published in the literature. A special attention has been paid to problems reported in CO₂ injection during a WAG (Water Alternate Gas) process. Observations are available from field cases, laboratory studies or numerical modelling. Data analysis showed that injectivity modifications observed are poorly explained. In most of the case, a loss of injectivity was reported due to:

- multiphase flow (relative permeability effects);
- CO₂/oil interactions;
- CO₂/minerals interactions.

In very few cases an increase of injectivity have been observed. Nevertheless, in the best case, the increase in injectivity is only 3 times the injectivity during water-flooding. From this survey study, some conclusions can be drawn, mainly applicable to injection in an oil reservoir:

- Concerning multiphase mechanisms, it is shown that relative permeability of CO₂ in presence of residual oil must be either lower or greater than water relative permeability in presence of residual oil. Consequently, no specific rule can be established and each case has to be studied.
- A lot of problems of injectivity losses are attributed to interaction between CO₂ and oil. The following phenomena can be found: miscibility problems, swelling, viscosity effects, precipitation of organic deposit—mainly asphaltene.

A lot of problems of injectivity have been reported and a few mechanisms have been studied, mainly in laboratory in

order to understand those complex phenomena. All mechanisms are very case-dependant and no general rules have been found. This domain clearly needs more investigation from a theoretical and experimental point of view, in order to predict the real injectivity of a well. In the case of CO₂ storage, huge amount of CO₂ will have to be injected (up to several millions ton/year for a typical power plant). It is therefore crucial to control and manage this injectivity issue.

GENERAL CONCLUSIONS

This review on injection technologies has identified several issues that have to be specifically addressed for:

- **Ensuring long-term safety of a CO₂ geological storage:** the well is a short-circuit between the storage and the surface or intermediate aquifers. Well materials and abandonment procedures have to be carefully designed to minimise the risk of CO₂ leakage through the well.
- **Ensuring a sufficient injectivity of the injection wells and the near-wellbore region in order to maintain the CO₂ flowrate:** For a typical coal-fired power plant, up to several millions of tons of CO₂ will have to be injected in the storage during 30-40 years. Operations in Sleipner and Weyburn are in this order of magnitude. For EOR operations using CO₂ injection like Weyburn, the number and location of injection wells is part of the optimisation of the oil recovery. In the case of CO₂ storage in a deep saline aquifer, a major economic target will be to minimise the number of injection wells. Due to the size of the Ustira aquifer in the Sleipner operation and to the high permeability of the sands, CO₂ can be injected at a high flowrate into a single well without any injectivity problems or significant pressure increase. In less favourable cases, injectivity may become a crucial technical and economical problem.

REFERENCES

- 1 Jarrell, P.M., Fox, C.E., Stein, M.H. and Webb, S.L. (2002) CO₂ Flood Environmental, Health and Safety Planning, chapter 9 of Practical Aspects of CO₂ Flooding. *Monograph 22, Society of Petroleum Engineers*, Richardson, TX, USA.
- 2 Corrosion in the Petrochemical Industry (1994) ASM International ed.
- 3 Hesjevik and Solsen, Seiersten, M. (2003) Institute for Energy Technology in Norway: Corrosion at high CO₂ pressure, Statoil & Institute for Energy Technology in Norway. *NACE International no. 03345*.
- 4 Seiersten, M. (2001) Institute for Energy Technology in Norway: Material Selection for Separation, Transportation and Disposal of CO₂. *NACE International no. 01042*.
- 5 Baklid, A., Korbol, R. and Owren, G. (1996) Sleipner Vest CO₂ Disposal, CO₂ Injection into a Shallow Underground Aquifer. *SPE Annual Technical Conference and Exhibition no. 36600*, Denver, USA, 6-9 Oct.

- 6 Krilov, Z., Loncaric, B., and Miksa, Z. (2000) Investigation of a Long-Term Cement Deterioration under a High-Temperature, Sour Gas Downhole Environment. *SPE International Symposium on Formation Damage Control no. 58771*, Lafayette, Louisiana, USA, 23-24 Feb.
- 7 Longworth, H.L. and Dunn, G.C. (1995) Underground Disposal of Acid Gas in Alberta, Canada: Regulatory Concerns and Case Histories. *SPE Gas Technology Conference no. 35584*, Calgary, Alberta, Canada, 28 Apr-1st May.
- 8 Hawkes, C.D., McLellan, P.J., Zimmer, U. and Bachu, S., (2004) Geomechanical Factors Affecting Geological Storage of CO₂ in Depleted Oil and Gas Reservoirs. *Petroleum Society Canadian International Petroleum Conference*, Calgary, Alberta, Canada, June 8-10.
- 9 Orlic, B. (2004) The Mechanical Impact of CO₂ Injection. *TNO-NITG-Information*, December.
- 10 Whittaker, S. (2004) The IEA Weyburn CO₂ Monitoring and Storage Project - Modeling of the Long-Term Migration of CO₂ from Weyburn. *IEA*.
- 11 Brosse, E. and Magnier, C. (2002) Piégeage de CO₂ dans les aquifères et les réservoirs pétroliers. *Poster AAPG*, Houston, TX.
- 12 Bazin, B., Bieber, M.T., Roque, C. and Bouteca, M. (1996) Improvement in the Characterization of the Acid Worm - holing by *In Situ* X-Ray CT Visualizations. *SPE no. 31073* presented at the *Symposium on Formation Damage* held in Lafayette, 14-15 February.
- 13 Bazin, B. (1998) From Matrix Acidizing to Acid Fracturing: a Laboratory Evaluation of Acid/Rock Interactions. *SPE no. 49491* presented at the *8th Abu Dhabi International Petroleum Exhibition and Conference* held in Abu Dhabi, UAE, 11-14 October.
- 14 Ross, G.D., Todd, A.C., Tweedie, J.A. and Will, A.G. (1982) The Dissolution Effects of CO₂-Brine Systems on the Permeability of UK and North Sea Calcareous Sandstones. *SPE/DOE no. 10685*, *Symposium on Enhanced Oil Recovery*, April 4-7, Tulsa, TX.
- 15 Grigg, R.B. and Svec, R.K. (2003) Co-Injected CO₂-Brine Interactions with Indiana Limestone. *SCA 2003-I9, Int. Symposium of the Society of Core Analysts*, September 21-24, Pau, France.
- 16 Svec, R.K. and Grigg, R.B. (2001) Physical Effects of WAG Fluids on Carbonate Core Plugs. *SPE no. 71496*, *Annual Technical Conference and Exhibition*, 30 September-3 October, New Orleans, LA.
- 17 Rogers, J.D. and Grigg, R.B. (2000) A Literature Analysis of the WAG Abnormalities in the CO₂ Process. *SPE no. 59329* presented at the *SPE/DOE Improved Oil Recovery Conference*, Tulsa, Oklahoma, 3-5 April.
- 18 Mathis, R.L. and Sears, S.O. (1984) Effect of CO₂ Flooding on Dolomite Reservoir Rock, Denver Unit, Wasson (San Andres) field, TX. *SPE no. 13132*, *Annual Technical Conference and Exhibition*, September 16-19, Houston, TX.
- 19 Dibble, W.E. and Potter, J.M. (1982) Effect of Fluid Flow Rates on Geochemical Processes. *SPE no. 10994*, *Annual Technical Conference and Exhibition*, September 26-29, New Orleans, LA.
- 20 Egermann, P., Bazin, B. and Vizika, O. (2005) An Experimental Investigation of Reaction-Transport Phenomena During CO₂ Injection. *SPE no. 93674*, *SPE Middle East Oil & Gas Show and Conference*, 12-15 March, Bahrain.

Final manuscript received in May 2005