



HAL
open science

Evolution of Refining and Petrochemicals: What Is the Place of Zeolites

C. Marcilly

► **To cite this version:**

C. Marcilly. Evolution of Refining and Petrochemicals: What Is the Place of Zeolites. Oil & Gas Science and Technology - Revue d'IFP Energies nouvelles, 2001, 56 (5), pp.499-514. 10.2516/ogst:2001040 . hal-02053956

HAL Id: hal-02053956

<https://ifp.hal.science/hal-02053956>

Submitted on 1 Mar 2019

HAL is a multi-disciplinary open access archive for the deposit and dissemination of scientific research documents, whether they are published or not. The documents may come from teaching and research institutions in France or abroad, or from public or private research centers.

L'archive ouverte pluridisciplinaire **HAL**, est destinée au dépôt et à la diffusion de documents scientifiques de niveau recherche, publiés ou non, émanant des établissements d'enseignement et de recherche français ou étrangers, des laboratoires publics ou privés.

Evolution of Refining and Petrochemicals: What is the Place of Zeolites*

C. Marcilly¹

¹ Institut français du pétrole, 1 et 4, avenue de Bois-Préau, 92852 Rueil-Malmaison Cedex - France
e-mail: christian.marcilly@ifp.fr

*This paper reproduces a Plenary Conference presented at the 13th International Zeolite Conference, 8-13 July 2001, Montpellier, France.
The text is reprinted from *Proceedings of the 13th International Zeolite Conference*,
Copyright 2001, Plenary PL-4, with permission from Elsevier Science.

Résumé — Évolution du raffinage et de la pétrochimie. Place des zéolithes — Dans une première partie, cet article décrit l'évolution passée (sur les deux ou trois dernières décennies) du raffinage et de la pétrochimie et tente de dégager les principales tendances de leur évolution à moyen et long terme. Il décrit ensuite les principaux défis que cette évolution place sur la route des acteurs du raffinage et de la pétrochimie.

Dans une seconde partie, il présente le marché des catalyseurs de ces deux domaines et le compare à celui des catalyseurs en général. Il présente ensuite le marché des zéolithes quelles que soient leurs applications industrielles (détergents, adsorption ou catalyse) et décline l'ensemble de ces applications en raffinage et pétrochimie. Il décrit l'évolution prévisible du marché des zéolithes et tente de dégager quelques directions possibles de progrès pour les zéolithes dans les activités de catalyse et adsorption appliquées au raffinage et à la pétrochimie.

Mots-clés : raffinage, pétrochimie, procédés catalytiques, hydrogène, soufre, dioxyde de carbone (CO₂), aromatiques, marché des catalyseurs, marché des zéolithes (dans les détergents, comme catalyseurs et comme adsorbants).

Abstract — Evolution of Refining and Petrochemicals: What is the Place of Zeolites — The first part of this paper presents the evolution of the refining and petrochemical industries during the last two or three decades and the principal trends of their evolution in the medium and long run. Then, it describes some important deals that both industries have and will have to cope with.

The second part gives some information on the market of catalysts for refining and petrochemicals. It presents the market of zeolites for various industrial applications (detergency, sorption/drying and catalysis) and details their applications in refining and petrochemicals. Then, it describes the probable evolution of the market of zeolites in the medium run and, at last, lists some examples of possible opportunities for zeolites to bring significant progress in catalysis and sorption applied to refining and petrochemicals.

Keywords: refining, petrochemicals, catalytic processes, hydrogen, sulfur, carbon dioxide (CO₂), aromatics, catalysts market, zeolites market (in detergency, as catalysts and as adsorbents).

GLOSSARY

Alkyl.	Alkylation
Atm. dist. (or distill.)	Atmospheric distillation
Conv.	Conversion
FCC	Fluid catalytic cracking
FO	Fuel oil
GO	Gas oil
HDC	Hydrocracking
HDT	Hydrotreatment
HDS	Hydrodesulfurization
Isom.	Isomerization
LCO	Light cycle oil (gas oil from FCC)
LPG	Liquefied petroleum gas
MTBE	Methyl-tertio-butyl-ether
Oligom.	Oligomerization
Polym.	Polymerization
POX	Partial oxydation
PX	Paraxylene
Reform.	Reforming
Str. run	Straight run
VB	Visbreaking.

INTRODUCTION

Refining and petrochemicals are the industries where zeolites are by far the most frequently used for adsorption and catalysis. The earliest application goes back to the end of the fifties, after the discovery by the company *Linde* of the synthesis of the A-type zeolite [1] capable of separating normal and branched paraffins. The second, and certainly the most significant event was the introduction of X and Y-type zeolites in catalytic cracking at the beginning of the sixties, which generated some deep technological changes in the process and substantial gains in gasoline yield. The first use of shape selectivity properties for zeolites dates back to 1968 with selective hydrocracking on erionite of normal paraffins of gasoline cuts. Over the last forty years, zeolites were introduced first in refining, and then in petrochemicals, and now hold what may be considered as a key position.

The future of zeolites in refining and petrochemicals is obviously for a large part, directly related to the evolution of these two sectors, and we will consider their development in the first part of this paper. In the second part, we will discuss the place occupied by zeolites among catalysts and adsorbents used in refining and petrochemicals, and will briefly discuss some possible potential application for the future.

1 REFINING AND PETROCHEMICALS: EVOLUTION AND CHALLENGES IN THE 21st CENTURY

Obviously it is not possible to discuss the long term prospects of these two domains of the petroleum sector seriously without referring to those of the petroleum resources that supply them.

1.1 The Future of Petroleum Resources

At the end of 1999, world proven reserves were estimated at some 145 gigatons (Gt) [2]. These proven reserves will be depleted in about 40 years at the present rate of consumption (3.4 Gt/year) [2] and in 29 years if the growth in world consumption is 2% a year.

The ultimate reserves are extremely difficult to assess, as there are many unknowns. The figures given, which depend on the nature of the reserves considered and the degree of specialists' optimism, vary considerably. For instance, the liquid hydrocarbon reserves (conventional and non-conventional crude and gas-associated liquids) are estimated at 370 Gt, *i.e.* 2700 Gbbl by the IEA (International Energy Agency) and at 645 Gt, *i.e.* 4700 Gbbl by the DOE/EIA (Energy Information Agency) [3].

Depending on which hypothesis is adopted at the outset, the world production in liquid hydrocarbons is expected to reach a maximum in about 2015-2035. Depending on the growth scenarios, ultimate reserves of 370 Gt should cover 60 to 100 years requirements [4, 5] and those of 645 Gt over 150 years. So the liquid hydrocarbon reserves are still substantial but their mobilization will demand significant efforts of research to make them usable [2]. Sometime in the middle of the 21st century, we will be turning to natural gas as the principal source of energy, coal and new renewable energies should remain at a modest level [6].

Although the present petroleum resources are quite sufficient to satisfy the requirements of the first half of the 21st century, their many and varied locations do pose a problem. The major part (66.5%) of the 145 Gt of proven petroleum reserves is to be found in a geographical zone (the Middle East) where the political climate is unsettled. The world will be depending more and more on this zone in the coming decades. Moreover, most consumer zones are far from producing zones, which leads to an intensive transportation activity.

1.2 The Demand in Refined and Petrochemical Products

1.2.1 The Development of Requirements from 1970 to the End of the 20th Century

Over the last thirty years, refining and petrochemicals have suffered an unsettled time with two oil crises (causing an economic downturn on a worldwide scale), the Gulf war and an awakening of awareness regarding the degradation of our environment.

Table 1 [2, 7] shows the development of the world petroleum consumption structure between 1970 and 2000. The following landmarks stand out:

- the heavy fuels sector dropped rapidly, from 30% in 1970 to 13% in 2000 (a sharp and massive drop in the demand of electric power stations). This decrease should continue but at a slower rate;

- by contrast, the part of light products increased during this period; especially that of middle distillates (jet fuels and gas oils) which increased from 27% to about 35% between 1970 and 2000 and is likely to continue to grow, mainly due to the increased number of diesel engines among the European automotive population, whereas the proportion of gasoline has remained fairly steady since 1970.

At the end of 1999, the world refining capacities were a little below 4.1 Gt, with a low growth rate of about 10% over ten years (3.74 Gt in 1989).

In petrochemicals, the demand in olefins stagnated between 1978 and 1982 and then picked up and has grown fairly steadily since then, a little over 5% a year on average, increasing from 65 to 126 Mt approximately between 1983 and 1997 [8]. This annual growth can be broken down as 5.3% for ethylene, 6% for propylene, 15% for isobutene and 2.2% for butadiene [9].

At the same time aromatics were increasing from 30 to some 57 Mt [8], with an average growth slightly under 5% between 1983 and 1997. During this period, benzene and especially PX, had the strongest growth, especially in South-East Asia. In 1997, the world production of benzene represented a little less than half of the production of monoaromatics (27 Mt) [10].

In the past thirty years, in order to handle changes in both the quantity and quality of demand, European refining has become more complex (*Table 2*), stepping up conversion capacity (FCC in particular) and installing new hydro-treatment (reduction of sulfur (S) content in fuels), hydrocracking and gasoline production units [11]. The trend is even more strongly marked in the Asia-Pacific region due to the fast development of certain countries in the zone (South Korea for instance). Figures were noticeably high in 1999 compared with 1989, and this was also due in large part to the fact that China has recently been taken into account (China has over one third of the FCC units in the Asia-Pacific region). In North America, hydrogenating processes (HDT and HDC) continue to progress, whereas the others (cracking and special processes) appear to be stagnating. On a global scale, world refining capacities showed a downturn in the eighties due to the petroleum crises of the seventies and the resulting economic slump. Refining capacities picked up again in the nineties under the stimulus of the reduction in the price of gasoline and the economic expansion of South-East Asia, among other things.

1.2.2 Development Forecast in Market Demand for Products in the Year 2010

Without any major changes in the policies applied regarding energy and crude prices, annual petroleum consumption should increase from 3.3-3.4 Gt/year in 1999 to over 5 Gt in 2020. In the coming decades, refining and petrochemicals

will probably be operating in a restrictive context marked, among other things, by the following political-economic requirements:

- the environment: more respect for the environment will be demanded, limiting the release of pollutant gases (NO_x, SO_x, volatile organic compounds), or discharge of contaminating liquids and solids, as much as possible;
- consumption: master consumption of petroleum products in order to limit gases with greenhouse effect (CO₂ in particular), which will also help to preserve non-renewable resources;
- growth: promote the growth of developing and newly developed countries whilst controlling pollution and consumption. Maintain minimum sustainable growth making it possible to absorb the technological mutations imposed by progress (policy of full employment).

Quantitative Demand

It is interesting to assess what world refining will look like in the year 2010, considering both a developed geographical zone and a zone being developed. *Table 3* [2] shows the development between 1990 and 2000 and that forecast between 2000 and 2010 in the demand for various petroleum products (especially gasoline, middle distillates and heavy fuels) in Europe (East + West), in the Asia-Pacific region (excluding Japan) and worldwide. The global consumption of petroleum products increases only very moderately in Europe (the same applies to the United States) but more significantly on a global scale due to the substantial contribution of developing countries, in particular Asia. As shown in *Table 3*, the least developed part of the Asia-Pacific region has caught up with Europe by 2000 and will be well ahead of it in 2010. The forecast for 2010 for global demand in petroleum products reaches the 1999 figure for global refining capacity (4.1 Gt approx.) which should therefore increase moderately in the coming years.

Regarding petrochemicals, the demand in olefins and aromatics is, and will remain steady. Between 1995 and 2005 the demand for olefins is expected to grow at a rate of over 4% on average, and that for aromatics by 3.6% [8]. Among the olefins, demand will typically be in the region of 4% to 5% for ethylene, 5% to 6% for propylene, 6% for isobutene and 3.3% for butadiene [9, 17].

Forecasts up to 2003-2005 for the global demand in aromatics shows a growth of all monoaromatics, but it will vary considerably according to the compound considered and according to information source [10]: it is in the range of 3.5% to 4.5% a year for benzene [10, 17], from 5% to 8% for PX approximately and significantly lower for the other aromatics [2, 10]. What stands out is the lack of balance between the growth in demand for benzene and xylene. The overall demand for petrochemicals should reach about 250 Mt in 2005 [8].

TABLE 1
Evolution of the structure of the demand in petroleum throughout the world
(market economy countries) between 1970 and 2000

	1970		1980		1990		2000	
	10 ⁶ tons	%	10 ⁶ tons	%	10 ⁶ tons*	%	10 ⁶ tons	%
Gasolines	492	25.4	626	26.6	750	26.8	876	26.2
Middle distillates	530	27.4	721	30.6	950	33.9	1163	34.8
Heavy fuels	608	31.4	645	27.4	500	17.9	426	12.8
Others	307	15.8	363	15.4	600	21.4	875	26.2
Total	1937	100	2355	100	2800	100	3340	100

Middle distillates: jet fuels, heating oil, diesel oil.

Others: refinery gas, LPGs, naphthas, solvents, lubricants, wax, bitumen, petroleum coke, etc.

* Approximate values.

TABLE 2 [12-16]
Development in the structure of world refining capacities between 1979 and 1999
and for the main geographical zones in Mt/year
(the zones that did not have a market economy in 1979 and 1989 are not included in these two periods but are integrated in 1999:
former Soviet Union, China, North Korea, several Eastern European countries, etc.)

	1979				1989				1999			
	N. Amer.	W. Eur.	Asia-Pacific	World	N. Amer.	W. Eur.	Asia-Pacific	World	N. Amer.	W. Eur.	Asia-Pacific	World
HDT	437	346	214	?	523	311	240	1290	577	404	374	1835
FCC	260	49	30	400	304	88	51	531	298	106	125	688
HDC	46	6	1	?	72	15	14	130	84	34	35	201
Atm. dist.	997	998	520	3210	870	832	500	2840	923	723	982	4077

HDT: hydrotreatments, FCC: fluid catalytic cracking, HDC: hydrocracking.

TABLE 3
Expected development of the demand for various petroleum products in Mt/year,
in the European Union (EU), Asia-Pacific and the world between 1990 and 2010 [2]

Years	Europe*			Asia-Pacific**			World		
	1990	2000	2010	1990	2000	2010	1990	2000	2010
Gasoline	138	153	168	114	183	253	746	876	1047
Middle distillates	235	303	342	174	312	451	950	1163	1472
Heavy fuels	90	77	60	82	104	132	504	426	456
Others	134	183	207	93	227	291	600	875	1046
Total	597	716	961	463	826	1127	2800	3340	4021

* Western + Eastern Europe (countries of former Soviet Union excluded) (Eastern Europe: ~10%-15% of Western Europe).

** Asia-Pacific except Japon.

Others: refinery gas, LPGs, naphthas, solvents, lubricants, wax, bitumen, petroleum, coke, etc.

Changes in Product Quality

Specifications regarding product quality have been getting increasingly stringent since the seventies, and this trend is most probably going to continue during the coming decade. The known or estimated development of specifications for the principal petroleum products in Europe between 1996 and 2010 is shown in Table 4 [2].

The most stringent specifications for gasoline and diesel fuel are on the sulfur contents that will be limited in 2005 to 50 ppm and then to 10 ppm: the 10 ppm S gasoline and diesel should be available in sufficient amounts in all member states by no later than 1st January 2005 and represent 100% of the total gasoline or diesel fuel by no later than 1st January 2011 (most recent proposal for a Directive on the quality of petrol and diesel fuels amending Directive 98/70/EC).

The gasoline pool is obtained by blending gasolines from various origins (Table 5): straight run, reforming, FCC, coking, hydrocracking, isomerization, alkylation, polymerization and additives (butane, ethers). Table 5 gives the average percentages of these various components in a gasoline pool for the United States in the nineties [2, 19-24] and in a Western European pool and indicates the main characteristics of each.

Most of these gasoline sources present various problems regarding changes in specifications:

- gasolines from steam cracking have a high content of S, benzene and other aromatics. This gasoline is not really suitable for the gasoline pool;
- FCC gasoline has a high content of S and olefins, with a somewhat poor octane number (MON for example). It must be hydrodesulfurized with the minimum octane loss;
- reforming gasoline is highly aromatic. The increased hydrogen production sought for the refinery will lead to an increase in the content of aromatic compounds, for which an outlet has to be found in petrochemicals. In all cases, the benzene content must be lowered;
- hydrocracking gasoline has inadequate octane. Rich in naphthenic structures, it provides an excellent reforming feed, but in this case adds to the production of aromatics which are likely to be excessive for the market.

The diesel fuel pool is also a mixture of basic products from various different origins (Table 6) [2, 21].

The sources of gas oil that raise problems are, in order of importance:

- FCC gas oil (LCO): it has a high S content and low cetane number and may be hydrotreated after blending (~ 30% for example) with straight run gas oil, but it is difficult to improve the cetane of the LCO (+ 6 to 15 points only depending on conditions) [20, 25];
- steam cracking diesel fuels: these have a very high content of aromatics especially dealkylated polyaromatics.

The typical aromatics content of most diesel fuels is more in the 30%-35% range, and although there are no particular specifications for the total aromatics content, this content is bound to drop due to the foreseeable evolution of S which will limit integration of LCOs and pyrolysis gas oils in the gas oil pool [26].

Pollutant emissions from automobile vehicles, whether running on gasoline or diesel fuel, do not depend much on the composition of the corresponding fuels. However, for new models of both categories of vehicle, the reduction of pollutant emissions will need technologies (lean burn engine, NO_x traps, etc.) which demand fuels with a very low sulfur content. The most stringent specifications on the S content adopted for 2005 and expected beyond mean further constraints for refiners in forming the fuel pools [2].

As regards petrochemicals, the general quality-related trend of the main products researched, olefins and aromatics, tends towards greater purity.

1.3 Changes in Refining Schemes [27]

Present tendencies and those in the coming decades regarding changes in refining requirements for catalyst processes, operate within a context marked by four key constraints:

- the almost total disappearance in the demand for heavy fuel oil with a high sulfur content (except for maritime heavy fuels) and the loss of the corresponding outlets for heavy residues;
- the need to have clean processes producing clean products to reduce polluting gaseous, liquid and solid discharge;
- an active concern about the risk of global warming (problem of CO₂);
- the maintenance of a policy for cutting costs at all levels in order to adapt to a constantly changing technical-economic world, and survive.

This being so, refining processes will be called on to evolve. As there are many processes, we will only be looking at them briefly and classifying them in three major categories: those that reduce the molecular weight of the feed (conversion), those that mostly modify the structure of the molecules without changing their size, while eliminating certain impurities (improved quality), and finally those that increase the average molecular weight of the feed (synthesis).

1.3.1 Conversion

Standard Conversion

The two major processes concerned here are catalytic cracking and hydrocracking which convert vacuum distillate type feeds (cracking can also absorb part of the atmospheric residue (AR)). In spite of the average or even inferior quality of the gasoline that it produces and the poor quality of some

TABLE 4
Evolution of specifications for three major petroleum products
between 1996 and 2005-2010 [2]

Specifications	Europe				Average California ⁽⁴⁾
	1996-1999	2000	2005	2011	
Gasoline					
S (ppm) max	500	150	50	10 (2)	18-20
Benzene (vol%) max	5	1	1	1 ?	0.4-0.6
Arom. (vol%) max		42	35	35 ?	23
Olefins (vol%) max		18	18	18 ?	3.5-4.0
Oxygen (vol%) max	2.7	2.7	2.7	2.7 ?	2.0-2.2
RON/MON min		95/85	95/85	95/85 ?	
Diesel fuel					
Density max	0.860	0.845	0.845	0.845 ?	0.842
S (ppm) max	500	350	50	10 ⁽²⁾	140
Cetane number min	49	51	51 ?	51 ?	53.8
Cetane index min	46	46	48 ?	48 ?	?
Dist. 95 vol% T max (°C)	370	360	360 ?	360 ?	?
Polyarom. (mass%) max		11	11 ?	11 ?	?
Domestic fuel					
S (mass%) max	0.2	0.2	0.2	0.1 ⁽³⁾	
Heavy FO					
S (mass%) max	2	2	1 ⁽¹⁾	1 ?	

(1) Probable maximum value for 2003.

(2) 100% of the total gasoline or diesel fuel by no later than 1st January 2011.

(3) Specification coming into force in 2008 but already taken into consideration in the choice of new HDS units to be built for 2005.

(4) [18].

TABLE 5
Components of the gasoline pool: typical contents and characteristics

Source	USA (%) [19-24]	W. Eur. (%) [2]	S (ppm)	Arom. (vol%)	Benz. (vol%)	Olef. (vol%)	RON	MON	RVP (kPa)
Distill.	3.8	7.5	100-200	2-4	1-2	< 1	65-80	60-75	70-80
Reform.	34.0	40	0	60-75	3-5	< 1	100	89	30-35
FCC	36.0	27	500-2000	25-35	0.7-1.5	40-50	93	80	40-50
Pyrolysis	~ 0	~ 0	2 to 4·10 ³	5-60	2-35*	20-35	82-96	74-85	70-80
HDC	2	~ 0	0	2-5	3	< 0.5	85	80	70-80
Isom.	4.5	10	0	< 0.5	< 0.5	< 0.5	85-88	82-85	70-80
Alkyl.	13	9	0	< 0.5	< 0.5	< 1	94	92	40-45
Polym.	~ 0	~ 0	0-150	< 0.5	< 0.5	> 95	95	82	60-70
Butanes	5	5.5	0	0	0	-	95	92	**
MTBE	1.7	1.0	0	0	0	-	113-117	95-101	55

* Benzene = low values in the case of low T pyrolysis (VB or coking) and very high in the case of steam cracking.

** 1% nC₄ → + 50 kPa.

TABLE 6

Components of the diesel pool: typical contents and characteristics [2, 21]

Source	W. Eur (%)	S (ppm)	Arom. (vol%)	Cetane	Cloud point
GO Str. run	70-90*	3 to 20·10 ³	20-40	42-54	-10 to +5
GO pyrolysis	< 5*	> 20·10 ³	30 to 60	28 to 45	-4 to -8
LCO FCC	< 10*	14·10 ³	60-85	18-27	-10
GO HDC	< 10*	< 20	8	> 60	< -15
GO Oligom.	~ 0	< 1	0	< 50	< -48
Fischer-Tropsch	0	< 1	0	≥ 75	-9

* After suitable HDT of sulfur-rich diesel fuels.

of its by-products (LCO and residue), catalytic cracking is an unavoidable and economic conversion tool in refining and its capacity on a worldwide scale is going to continue to grow.

Deep Conversion

The drop in demand for heavy fuel oil which is expected to continue in the coming years and the continuous growth in the demand for white (light) products, should promote the increase in capacities for the conversion of residues and more specifically vacuum resid (VR). However, due to the high investment costs required, the present low profitability of this conversion, and the existence of alternative solutions (exporting of residues, sourcing with lighter crudes with a low sulfur content, reorganizing existing units, etc.), refiners have adopted a “wait and see” attitude and will continue to do so for the next few years. This development of refining should be looked at as a medium, or rather a long term (5 to 15 years) solution. So catalytic conversion tools can be expected to take the lion’s share, thermal processes (coking and thermal cracking) which are much less selective being kept for highly contaminated residues [28].

The hydrotreatments required for deep conversion demand additional hydrogen to make up that supplied traditionally by the refinery reformer. The new source of hydrogen may be supplied by a gas steam-reforming unit, but more often by partial oxidation of the ultimate residue as it makes it possible to totally convert the residue into synthesis gas.

1.3.2 Petroleum Cut Quality Improvement

Between 1990 and 1999, the global capacity of hydro-treatment had already increased by more than 40% and is expected to continue to grow in the coming years. Certain cuts that escaped hydrodesulfurization in the past will have to undergo this treatment in the future (certain kerosenes and straight run gas oils or FCC gasolines).

In order to satisfy the octane requirements for gasoline, C₅-C₆ isomerization units will become more common,

whereas reforming will continue to grow but a little more slowly. Today, reforming is unavoidable as a provider of hydrogen and a high octane number gasoline, and the very low pressure operation also allows significant progress for these two objectives but produces more aromatics. The latter should be introduced in limited quantities in gasoline, and petrochemicals should absorb at least part of the excess production.

Concerning the improved quality of gas oils and lube oils, of which a steadily increasing proportion will be provided by hydrocracking, it will be necessary to build units for the controlled hydroisomerization of long paraffins contained in these cuts in order to improve the cold resistance while minimizing losses through cracking.

1.3.3 Synthesis Processes

The processes concerned are more particularly: aliphatic alkylation, olefin oligomerizations and etherifications [28].

The gasoline obtained by isobutane-olefins alkylation is an ideal component for the gasoline pool through its substantial contribution to the octane number and the absence of aromatics and olefins. The technologies used go back a long way and are technically well mastered, but the liquid catalysts used pose some problems: human risk regarding hydrofluoric acid, large quantities of waste (“red oils”) that have to be retreated for the sulfuric acid. These problems somewhat slow down development which would otherwise be rapid.

Oligomerizations make it possible to produce high octane number gasolines, but their strong olefinicity demands saturation by hydrogen. These processes will probably only have a limited growth in the future. The production of gas oil by oligomerization will remain marginal as the cetane number obtained barely exceeds a value of 50.

Etherifications are proven processes which do not raise any specific problems and should spread rapidly unless the banishing of ethers from gasolines decided in California spreads to the rest of the United States and then the world.

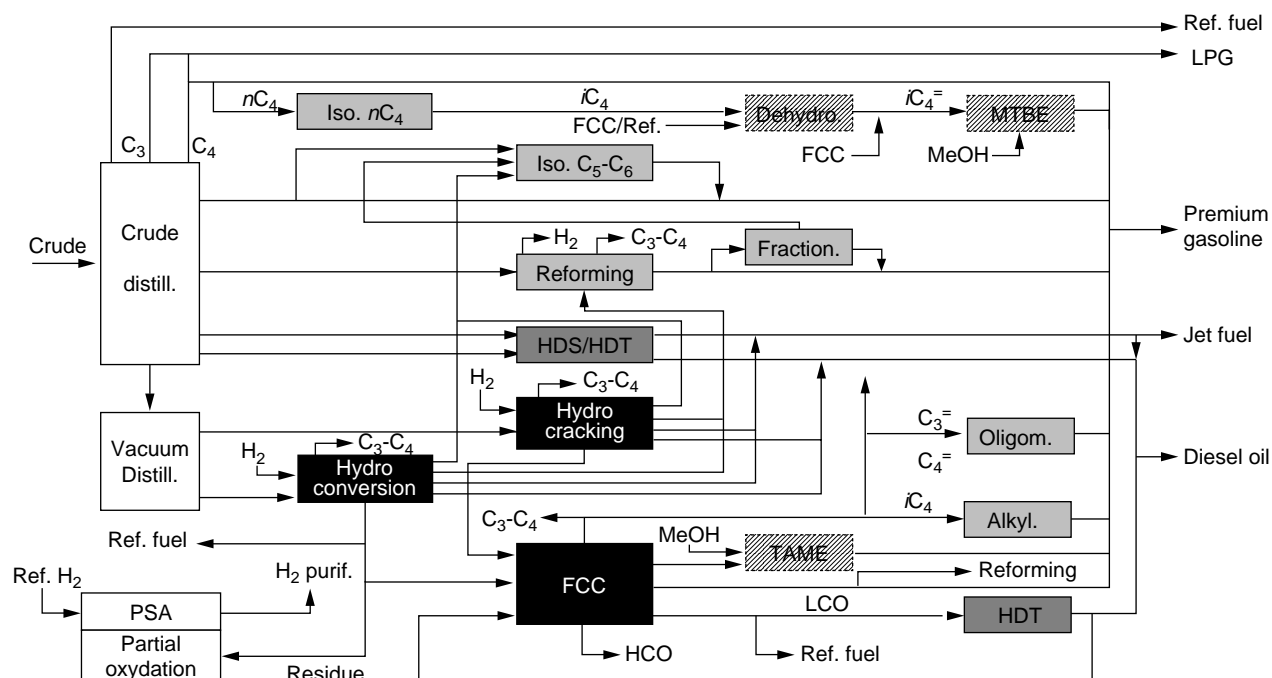

Figure 1

Refining scenario for 2010 [29].

1.3.4 Refining Scenarios for 2010

Figure 1 [29] shows a typical refining scheme for 2010 and the rest of the decade. Every refinery would not be able to house all the installations presented, as the corresponding investments would be too heavy. However, overall, the refineries in the same oil corporation should correspond more or less to this scenario. It includes deep conversion units with a POX for residues for refinery hydrogen production, hydrotreatments on all the distillation cuts and the LCO of the catalytic cracker and specific additional units for quality improvement: isomerization of light paraffins, aliphatic alkylation and etherification.

1.4 New Deals for Refining and Heavy Petrochemicals

1.4.1 Refining, Hydrogen and Self-Consumption

The expected evolution for refining (deeper hydrodesulfurization, better product quality and finally, in the long run, deep conversion) means a significant growth in the hydrogen requirements of the refinery [28, 29]. Compared with the simple refinery (hydroskimming) of the seventies and eighties, the hydrogen demand of the whole refinery in 2010 and beyond shown in Figure 1 could be multiplied by a factor in the order of 5.

The production of hydrogen would be one of the principal reasons for the increase in self-consumption. This increase would be very limited to start with in classic refineries that will gradually be acquiring the equipment to comply with the new specifications imposed, without going so far as to install a resid hydroconversion or a POX unit. It is thus expected that the increase will only be from 6% to 7% of the crude treated in the European Union between 1996 and 2010 thanks to the savings made at the same time by the refiners [11], especially through the use of co-generation on a much larger scale. But as shown in Table 7 [2], it could become significant for a complete refinery corresponding to the scenario on Figure 1.

The production of hydrogen by steam-reforming of methane or by partial oxidation of heavy residues (POX) inevitably leads to additional emissions of CO₂ due to the increase in self-consumption.

1.4.2 Refining and Sulfur

Gaseous sulfur emissions coming from the refineries and their products, represent a risk for the environment (acid smoke and acid rain) and a health hazard. Also gas emissions containing sulfur from the combustion of fossil fuels inhibit the catalysts of exhaust systems. This is the reason why the level of 50 ppm fixed for 2005 for gasoline and gas oil is only a step towards levels closer to zero [2, 30].

TABLE 7

Evolution of investments, self-consumption and of the hydrogen demand for an average refinery

Type of refinery	Investments (G\$)	Self-consumption (wt% of crude)	H ₂ consumption ⁽³⁾
Simple	0.5	~ 4	α
Classical conversion	1-1.5 ⁽¹⁾	~ 6	$2\alpha-3\alpha$
Deep conversion ⁽²⁾	2.5	~ 10	5α

(1) According to product quality.

(2) Including specific units devoted to improving quality.

(3) The figures given are not absolute, as the hydrogen consumption, and therefore of α , will depend on operating conditions (nature of the treated crude, S content of the products, etc.).

Figure 2

Evolution of the distribution of sulfur leaving a refinery between 1996 and 2005 [31].

Regulations regarding the sulfur contents of petroleum products and sulfur emissions from the refinery, mean that most of the sulfur is now recovered in Claus and Claus tail gas units in the refinery in the form of elemental sulfur.

Figure 2 shows the changes between 1996 and 2005 in the distribution of sulfur leaving an average-sized refinery treating 8.1 Mt/year of a crude with 1.13% S (*i.e.* 91,506 t of S). Part of the sulfur leaving the refinery is distributed among the products and gaseous emissions of the refinery, the rest is collected in the form of elemental sulfur. Between 1996 and 2005, the part of the sulfur in the gaseous emissions drops significantly, but it is mainly that present in the refining products that is reduced (from 51% to 37%), leading to a substantial increase in elemental sulfur production (from 41% to 57%) [31].

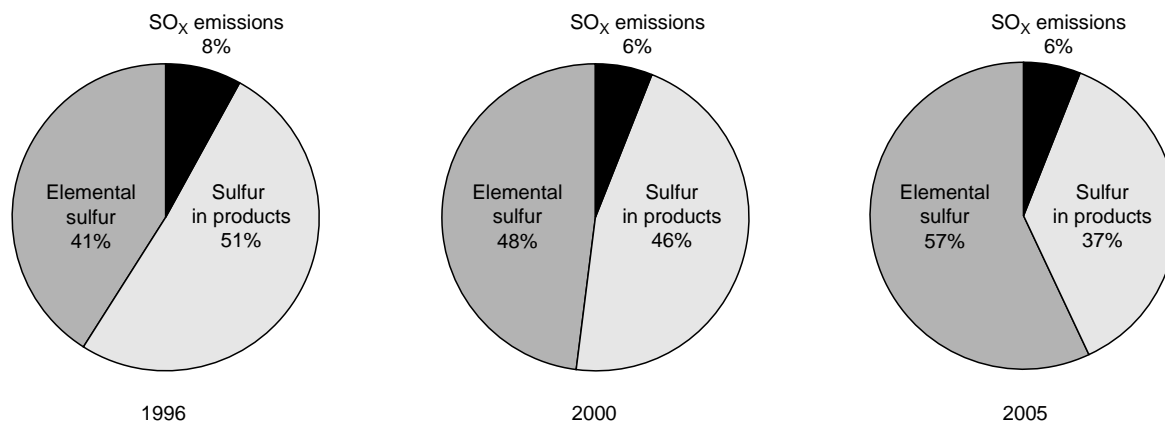
Refining is now a major sulfur producer, and will become even more so. For instance, a large refinery, such as that of *Shell* at Rotterdam which treats some 20 Mt crude a year, already produces between 250 000 and 300 000 tons of S per year [32].

The production of S worldwide (inclusive of all forms) in 1998 was about 62 Mt, with 40.5 Mt in the form of elemental sulfur [32] produced mainly by refineries (approximately 1/3) [33] and natural gas. This figure is expected to increase

to 68.5 Mt in 2003 and then 74.5 Mt in 2008, with 47.8 and 53.1 Mt respectively of elemental S, the proportion of S recovered from fossil hydrocarbon sources increasing steadily. At the present time the zones with the highest S production (inclusive of all forms) are North America which comes far ahead of Asia and Europe [32].

The main outlet for S is sulfuric acid (90% approx.) with the two main outlets for utilization being fertilizers (approximately 60% of S) and chemicals (textiles, solvents, paints, detergents, etc.) [31, 34]. However, certain outlets (H₂SO₄, CS₂) are expected to have a lower demand by the year 2008 [35].

For several years, the offer of sulfur has already exceeded the demand, which has led to significant lowering of prices [34, 36, 37]. Over about fifteen years, the price of sulfur has therefore dropped from a value of over 100 \$/t to much lower values fluctuating between 45 and 65 \$/t. The coming decades are likely to be marked by an even greater production excess [32, 36, 37]. Initially a valuable industrial product, sulfur has become a by-product, which has already made some traditional production sources unprofitable and forced them to cease activities. It is fast on the way to becoming a waste if new outlets are not discovered [37].

1.4.3 Refining and CO₂

In addition to the limitation of traditional atmospheric pollutants such as the sulfur and nitrogen oxides and hydrocarbons, we now have to consider the reduction of greenhouse gases, in particular CO₂.

CO₂ in the Atmosphere and the World Climate

Carbon dioxide is said to be the main culprit in global warming. Although the heating power attributed to it is considerably less than that of other pollutants (about 30 times less than CH₄ and 200 times less than N₂O), the significant CO₂ contents in the atmosphere mean that this gas is the principal contributor to the greenhouse effect (about 55% in 1990) [38].

The coinciding of industrial development of human society and the increase in the CO₂ content in the atmosphere explains why the latter is considered as being mainly due to human activities. Since 1860, at the beginning of the second industrial revolution (the time when electricity and petroleum were discovered), the average concentration in CO₂ in the atmosphere has increased from 288 ppm to 315 ppm in 1957 and 368 ppm in 2000, meaning an increase of almost 30% in 140 years [39]. Experts predict that this tendency will continue reaching a possible figure of 600 ppm in 2050.

The awareness of the risk presented by CO₂ for the future of the climate began well before 1990, and in spite of a lack of knowledge and perspective making it difficult to grasp the true validity and full impact, ecologists and many scientists called for preventive measures to be taken urgently [40]. The Kyoto Protocol, adopted on 10 November 1997 within the framework of the master convention of the United Nations on the climate change, and appealing to industrialized countries to reduce their greenhouse gas emissions by an average of 5% by 2010 compared with 1990, could not be respected, because for one thing the time-line was too short to allow effective technologies to be developed and diffused [41], and for another thing, there is reason to doubt the motivation of a certain number of countries implicated. However, even although the Summit of The Hague in November 2000 did not end in the hoped for decisions being taken, in the coming years, we can expect CO₂ emissions to be increasingly taken into account at all levels of human activity.

The Role of Human Activities in the Total CO₂ Emissions Worldwide

Out of the 28 Gt of CO₂ released every year into the atmosphere by human activities, some 21.5 do in fact come from fossil fuels and the rest, *i.e.* 6.5 Gt are due mostly to deforestation [34, 42, 43]. The figure of 28 Gt does indeed appear low compared with the 770 Gt/year of natural CO₂ emissions (*i.e.* 96.5% of the total emissions) [43], and from this view point industrial activities (industries, electric power stations) and those related to transport would only be

responsible for 2.2% of global emissions and petroleum only for 1.3% [44, 45]. But unlike natural emissions which are part of a natural carbon cycle and are offset over one year by the same volume of CO₂ that is absorbed or transformed, these 28 Gt would be considered as an excess volume of emissions only partly offset in the yearly cycle of CO₂. It is generally accepted that a minimum of 120 years would be necessary to return to the initial situation of 1860 if CO₂ were to be brought back to its level at that time [39].

Table 8 [43] which shows the emissions of CO₂ worldwide according to type of human activity, shows that transport is responsible for a little less than 20% of these emissions. But emissions due to transport are essentially a phenomenon of developed countries. For instance in the United States, transport contributes 32% of CO₂ emissions, three quarters being due to road transport [46].

TABLE 8
Annual emissions of CO₂ due to human activities (1996)*

Activity	% of 28 Gt	% of total emissions (800 Gt)
Electric power stations	25	0.875
Residential and tertiary	23	0.805
Industry	19	0.665
Transport	18	0.63
Private vehicles	5.5	0.19
Trucks	6	0.21
Planes	3	0.1
Ships	1.5	0.05
Others	2	0.07
Burning of the biomass	15	0.525

* These CO₂ emissions differ significantly from one geographical region to another.

Refining and CO₂: Need to Adopt a Rational Approach [47-49]

The impact of measures taken regarding CO₂ should not only be considered in terms of emissions from motors but must be the result of an overall assessment from the time the crude enters the refinery up to the end use of finished products. Such an assessment would inevitably point to the necessity to find compromises:

- a first and short term compromise should be found between the reduction of the sulfur and the increase in refinery self-consumption. Low sulfur content fuels, the production of which is responsible for an increase in CO₂ emissions, is only necessary for vehicles fitted with new technologies. Therefore, it is not necessary to supply the whole automobile population with these fuels as early as 2005 when the major part of the population will not yet be fitted with the new technologies [50]. This has been taken into account in the most recent proposal of Directive of

the European Parliament and Council that imposes a progressive replacement of the 50 ppm S gasoline by a 10 ppm S gasoline between 2005 and 2011;

- a second compromise between the other specifications set for fuels in 2005 and the increase in self-consumption had also to be found. Some of these specifications are effectively interdependent and this interdependence will be probably taken into account in the next Directive of the European Parliament and Council. For instance, in the future it would not be necessary to keep the aromatics content below 35% in gasoline if the almost complete elimination of sulfur enables total elimination of harmful hydrocarbons discharged in exhaust gas [50]. A similar remark can be made regarding the lowering of the T95 and polyaromatics in diesel fuel which aims at limiting the formation of soots in exhaust gas, when all diesel vehicles will probably be fitted with particle filters in the future [50];
- balancing the production of finished refinery products is also a kind of compromise and a less well-known way of minimizing CO₂ emissions: the example given below shows that adopting a position outside the large domain of acceptable variations for ratios between the production of gasoline and gas oil, has a negative impact on energy consumption and therefore on refinery CO₂ emissions. Actually, these emissions, although significantly lower than those of vehicles running on gasoline and diesel fuel (approximately 7 to 8 times less) [47] are far from negligible.

Extreme operating limits of a refinery, the principal conversion tool of which is the FCC, correspond to middle distillates/light distillates (light distillates = gasolines) (MD/LD) ratios which are roughly equal to 1 and 2. Between these two values, the refinery modifies the gas oil/gasoline ratio of its fuel production by playing on the nature of the crude supply and the cut points of the products, but globally, CO₂ emissions remain more or less constant.

The MD/LD ratio equal to 2 corresponds to a proportion of diesel engines of the automobile population of about 25%. At the present time, a country such as France has already, in the year 2000, a 33% proportion of diesel engines (MD/LD ratio of 2.3 approx.) and should reach 37% in about 2005. By contrast, the American situation corresponds to an unbalanced market in the other direction, with an MD/LD ratio that is well below 1 (about 0.6). It is therefore interesting to find out what happens to the CO₂ emissions on either side of the previous operating range.

Figure 3 [48] shows that any significant imbalance between the gas oil and gasoline productions lying either on the “all gas oil” side or on the “all gasoline” side of the “optimum equilibrium” range generates a rapid increase in the CO₂ emissions in the refinery.

If France had to produce its own diesel gas oil, it would have to carry out some large scale installation work in hydrocracking units, or even hydroconversion of residues,

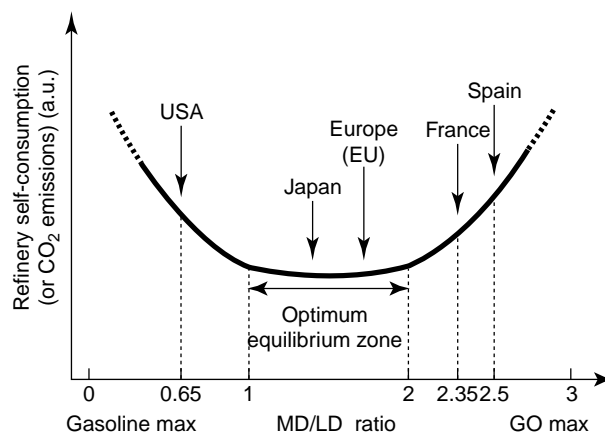

Figure 3

Impact of a change in the ratio between middle distillates and light distillates on refinery self-consumption (middle distillates = jet fuel + diesel oil + FOD; light distillates = gasolines) [48].

which would lead to a sharp increase in global CO₂ emissions. Other European countries also encourage the sale of cars running on diesel fuel, and from this point of view, a country such as Spain is at present European leader with 49% licensing of new public vehicles running on diesel against 39% for France and 25% for the European average. By contrast, excess emission of CO₂ corresponding to the American situation is due mainly to the need to produce gasoline by a deeper conversion of the crude (including by hydrocracking of the FCC LCO) which means an increase in refinery self-consumption. At the present time, excess emission of CO₂ is partially avoided in France, through an intense import-export activity. In order to ensure a balance between offer and demand, France imports gas oil and exports its excess gasoline, but manages to generate less pollution than the United States where the opposite is the case. This situation is obviously precarious and can be disrupted by any change in the energy policy of one of the actors.

This confirms we are still far from a rational global approach and that much progress is to be made in reducing worldwide CO₂ emissions due to refineries.

1.4.4 Stronger Interaction Between Refining and Petrochemicals in the Future [51-54]

Faced with the complexity of the demands and increasingly stringent constraints, the two industries, refining and petrochemicals, will gradually have to tighten the bonds which had become somewhat slack over the last two decades. They will have to strengthen their exchange of products and make the most of all opportunities of complementarity in

order to adapt to the new economic context. The following points can be given as examples:

- evolution of steam cracking feeds: less availability of light naphthas, more and more frequently used by refining for reformulated gasoline, will oblige petrochemicals to look towards lighter feeds (petroleum gas, non-olefinic C_3 - C_4 cuts from refineries, as well as gas condensates which could become significant feeds in the future) or towards heavier petroleum cuts with higher aromatic contents;
- recovery of light olefins for the petrochemical industry from a certain number of refinery effluents: refinery ethylene gas, propylene from the FCC LPGs;
- recovery of effluents rich in hydrogen for the refinery and of isobutene and isopentenes from the steam-cracking C_4 and C_5 cuts respectively, for the production of ethers if these are not prohibited in gasolines;
- recovery of aromatics extracted from gasolines: by the year 2005, there will be a surplus of aromatics on the European market. The problem is that the European and world markets for aromatics are small compared with the corresponding gasoline markets (Fig. 4) [18]. Thus the 1998 European market of aromatics is 13 Mt which breaks down into 6.5 Mt of B, 2 of T, 2.5 of X (mixture) and 2 of isomers (OX + PX) [18]. The 1998 European market (East + West) for gasoline was about 168 Mt and the world market of 975 Mt [2]. Every percent of benzene in world gasoline represents about 1.5 times the European benzene production, *i.e.* ~ 9.7 Mt. The 2000 specifications on benzene and aromatics (1% and 42% in gasoline respectively) [18] could have originated a large excess of these aromatics, especially benzene, on the market. This did not

happen: the largest part of the benzene excess was either avoided or transformed into refineries and the rest was absorbed by petrochemicals. However the limit of 35% for aromatics in gasoline expected for 2005 will probably mean a further excess of over 10 Mt on the European market if all the aromatics were to be extracted [18]. Such a quantity of aromatics could not be absorbed by the market and would cause prices to collapse [18]. In such a situation, only the refineries that are large enough with a good enough performance could allow themselves to produce low cost aromatics. The others would have to find other solutions;

- use by the refining sector of processes initially developed by petrochemicals such as steam-reforming of natural gas, partial oxidation of residues, Fischer-Tropsch synthesis, etc.

2 CATALYSTS IN THE REFINING AND PETROCHEMICALS INDUSTRY: IMPLICATIONS AND OPPORTUNITIES FOR ZEOLITES

2.1 Catalysts: World Market

In 1999, the world market for catalysts (including precious metals) reached G\$9 with 24% for refining, 23% polymers, 24% chemicals and 29% environment.

Table 9 gives the refining catalyst market in tons and dollars by application for 1999 and 2005 [2].

En 1999, North America accounted for about 30% to 40% of the market in dollars depending on the sources of information [2, 55, 56] and Western Europe for 20%. In 2005, their respective shares will be about 35%-38% and 19% of this market.

The world market of solid catalysts for refining represented G\$2.16 and about 640 kt in 1999 and will probably account for G\$2.6-G\$2.7 and 750-760 kt in 2005 [2].

2.2 Zeolites: Applications and General Trends of Development

2.2.1 Zeolites: Main Fields of Application and Markets [2, 57, 58]

The world zeolite market has developed strongly over the last decades and at present represents some 1.6 Mt per year [58], with about 290 000 t/year for natural zeolites (approximately 18%) used in ionic exchange and adsorption.

Applications of synthetic zeolites concern three major fields of activity amounting to some 1.3 Mt: detergents (A-type zeolites), adsorbents and desiccants (A and X-type zeolites mainly) and finally catalysis (especially Y-type zeolite). In 1998, the world market for these synthetic zeolites was approximately G\$1.6, of which catalysis represented a little over 50% [2]. As shown in Table 10

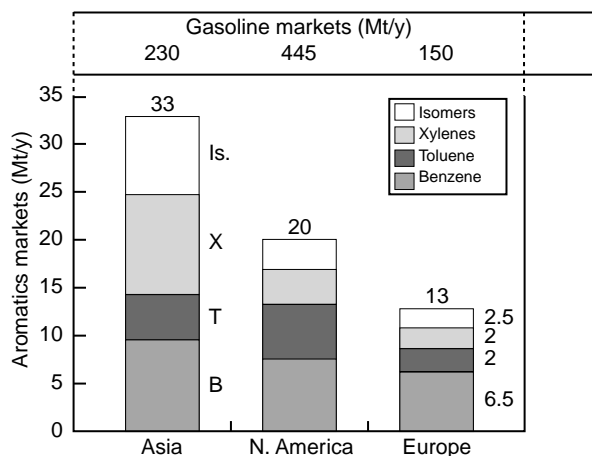

Figure 4

1998 markets of aromatics in Asia, North America and Europe compared with corresponding markets and world markets of gasoline [18].

TABLE 9
World catalyst market in refining

Processes	1999			2005		
	10 ³ tons	%	G\$	10 ³ tons	%	G\$
Cracking	495	77	0.7	560	73.6	0.83
Hydrotreatments	100	15.5	0.72	135	17.7	0.96
Hydrocracking	7	1.1	0.10	9	1.2	0.12
Reforming	6	0.9	0.12	7	0.9	0.15
Others*	~ 35	5.5	0.56	~ 50**	6.6	0.64
Total solids	~ 640-650	100	2.2	~ 760	100	2.7
Alkylation	3100**	–	0.85	3700*	–	1

* Catalysts for H₂ production, polymerization, isomerization, etherification, Claus, lubes, etc.

** Approximate values.

TABLE 10
Consumption of synthetic zeolites in thousands of tons (1998)

	N. Amer.	W. Eur.	E. Eur.	Japan	Other	Total
Detergents	275	505	55	85	130	1050
Catalysts	80	25	15	10	30	160
Adsorb./Desic.	43	27	5.5	6.5	18	100
Total	398	557	75.5	101.5	178	1310

which gives these fields of activity according to major geographical regions, the share of catalysis in tons is much less and only represents a little over 12%.

The expected evolution over five years (up to the year 2003) is on average a moderate global growth in the order of 1% to 1.5% per year approximately for catalysis, from 1% to 2% for adsorbents and desiccants and, for detergents, a slight decrease on average (~ 1%-2% per year) in the major developed countries (lower quantities of zeolite in detergents).

Out of the 1.3 Mt of synthetic zeolites produced annually, the A-type zeolite, with 1.1 Mt, is by far the most commonly used [58]. Its principal field of application is in the detergent industry, where certain modern detergents contain up to 40% weight.

About 100 000 t per year of synthetic zeolites go to the adsorption sector [58-60]: desiccation and purifying standard applications (insulating windows mostly, refrigeration, treatment of natural and industrial gas, purification of olefins, desiccation of alcohols) and separations (*n*-paraffins, xylenes, PSA/VSA systems for the production of oxygen or hydrogen, etc.). Among the zeolites used, the A-type zeolite is in a large majority [58] for desiccation and separations in particular, followed by X-type zeolite for the elimination of traces of polar impurities, and, to a lesser degree, by various zeolites with high silicon contents such as mordenite and ZSM-5 for

desiccation of acid gases or the elimination of volatile organic compounds.

Regarding catalysis, almost all the zeolites used in the world are used in refining and petrochemicals. In refining, the principal applications are cracking (FCC), hydrocracking, isomerization of C₅-C₆ cuts and dewaxing or isodewaxing. In petrochemicals, the principal use is in aromatic transformation (alkylations, isomerization, disproportionation/transalkylation) which, in 1999, represented 8.4% and 6% respectively of the financial volume and tonnage of petrochemical catalysts, *i.e.* about 2% of the financial volume of world catalysts. The Y-type zeolite present in the FCC catalysts alone accounts for almost 95% of the world consumption.

Speciality zeolites, which account for only a few percents of the world consumption of zeolites in catalysis, are mainly Y-type zeolites modified for hydrocracking and ZSM-5 zeolite as FCC additive. The production of other zeolites remains marginal.

In all, out of some 130 known zeolitic structures, only about a dozen are used in industrial or pre-industrial applications [2, 61, 62]; these are the following:

- A detergents, desiccation and separation
- FAU X (desiccation, purification, separation) and Y (separation, catalysis)

MOR	adsorption and catalysis
LTL	KL-type zeolite (catalysis: aromatization)
MFI	silicalite and ZSM-5 (adsorption and catalysis)
BEA	beta-type zeolite (catalysis: cumene)
MTW	zeolite MCM-22 (catalysis: ethylbenzene, probably cumene?)
CHA	SAPO-34 (methanol to olefins or MTO process-demonstration unit)
FER	ferrierite (skeletal isomerization of <i>n</i> -butenes-demonstration unit)
AEL and /or TON	SAPO-11 and possibly ZSM-22 (improvement of pour point for petroleum cuts by straight long paraffin isomerization)

and structures not revealed (for aromatic C₈ isomerization): one is certain (*IFP*) and the second is possible (*UOP*).

2.2.2 Openings for Zeolites in Refining and Petrochemicals

Zeolites have been present in refining since the beginning of the sixties (FAU cracking) and in petrochemicals of first generation intermediaries since the seventies (transformation of aromatics on MOR). The success of zeolites in second generation intermediary chemistry and fine chemicals [63-73] are on the whole, more recent [63-70, 72, 73] and benefit from the zeolitic materials developed mostly for the first two industries. Significant improvements of these materials are still possible, and new applications using new materials or not yet used so far, will be emerging in the coming decades. However, it is very likely that from this point of view, fine chemicals will be more profitable than more mature industries like refining and petrochemicals for at least two reasons:

- the variety of reactions is greater and the catalysts far from optimized;
- the products have an added value that is greater and may make the high cost of certain zeolitic material acceptable. However, the quantities of products involved in the fine chemicals sector are small, and the volumes of zeolitic materials used will still be minor compared with those of refining.

Considering the specifications imposed relating to petroleum products in general and fuels in particular, the refining industry and that of petrochemicals has, and will always have a need for new or improved adsorbents and catalysts. From that point of view, zeolites will continue to hold a strong position to offer innovative solutions. The opportunity concerning the progress that they can provide must be sought first of all in existing processes or new processes aiming at producing the following hydrocarbons:

- light olefins from C₃ to C₅ as raw materials for petrochemicals or for the production of clean, good quality fuels;
- highly branched paraffins from C₅ to C₁₂ for the gasoline pool or longer and slightly branched paraffins for the kerosene and gas oil pools;

- specific molecules as first and/or second generation intermediaries in petrochemicals: alkylmonoaromatics in particular. The development of processes of inter-transformation of these aromatics can certainly be expected.

More precisely, the following few opportunities for zeolites can be mentioned:

- FCC: although it is not likely that the Y-type zeolite will be replaced as principal active agent, there may be room for additives enabling selective production of light olefins ranging from propylene to pentenes as long as these additives are competitive with the ZSM-5 regarding costs, activity and stability;
- hydrocracking: the main factor for progress here would be to find a zeolitic catalyst dedicated to the production of middle distillates, associating both the activity and the stability of zeolites and the selectivity of amorphous catalysts;
- aliphatic alkylation: the best zeolite found to date is the beta-type zeolite, which does not contribute any octane gain compared with existing processes. A three-dimensional zeolite, more open than the beta and at least as active, would be needed for this application;
- isomerization of paraffins: in the domain of middle paraffins from 7 to 9 carbons of the gasoline fraction, there is a need for a catalyst making it possible to achieve a thorough isomerization selectively (2 branches or more) while minimizing the cracking. However this is a difficult challenge for a bifunctional acid catalyst;
- dewaxing (gas oils, HDC residues, lube oils): recent innovations in this domain (dewaxing by hydroisomerization) represent a significant breakthrough compared with classic processes by hydrocracking (on MFI structure). Progress is still possible in particular to further limit loss through cracking of isomerized products at high conversion;
- hydrodecyclization of polyaromatics of middle distillate cuts (LCO in particular) remains a significant challenge. The difficulty which acid catalysis comes up against is that the cycle opening is generally slower than the consecutive cracking of open products;
- transformation of aromatics: nearly all catalysts used are zeolitic. New zeolites can still provide gains in selectivity and stability. Also, the alkylation of aromatics other than benzene is of interest (ethyltoluene, isopropylbenzene, disopropylbenzene, paraethyltoluene, alkyl-naphthalenes and dialkyl-naphthalenes, etc.);
- hydrotreatments: several studies have made it possible to detect some interesting potential among certain metal sulfides dispersed in the zeolites to desulfurize and denitrogenate certain refractory heteroatomic molecules (certain alkyl-dibenzothiophenes for example). One of the difficulties that has to be solved is to avoid excessive cracking of the hydrocarbons to be purified;

- in the field of adsorption/separation, significant progress can be expected with the optimization of materials that are already known (crystalline defects, Si/Al ratios, nature and position of cations, external surface properties, crystal size, etc.) and the discovery of new materials;
- zeolitic membranes: In spite of many studies carried out since the eighties, the penetration of zeolitic membranes in industry has been very slow and has still not been integrated in refining and petrochemicals activities. These do however, represent an important application potential in the long term in the domain of molecular separation for certain catalytic separations. Considerable progress remains to be made regarding manufacture of these membranes [74].

CONCLUSION

The global demand for petroleum products and therefore the capacities of refining and petrochemicals will continue to grow for many years to come. Refining and petrochemicals can be considered, by certain aspects, as mature industries, but this is only an appearance for these industries are constantly changing. For the last three decades, refining schemes have indeed evolved and progressed considerably. They continue to change to adapt to numerous constraints which are not likely to decrease in the foreseeable future, and which are due to the need to limit consumption of petroleum products (in particular CO₂-related issues), to have greater respect for the environment and minimize refining costs.

In this context, zeolites have an important role to play. The contribution of zeolitic catalysts to refining and petrochemicals is already substantial. We can hope for further achievements in the future through improvements to existing catalysts and the development of new catalysts, as the association of the properties of acidity and shape selectivity offered by zeolites is unique. These achievements could occur in a wide variety of domains, affecting not only the major processes of hydrorefining and conversion, but also smaller capacity, more specialized processes. But the development of any new process always comes up against the unavoidable need to be profitable and competitive, which is often a difficult obstacle to overcome.

ACKNOWLEDGEMENT

I would like to express my gratitude to a number of people at IFP for their help in providing technical and/or economical information: M. Baraqué, O. Clause, L. Cuiec, G. Fournier, L. Kerdraon, J. Larue, A. Methivier, X. Montagne, I. Prevost, J.B. Sigault.

Additionally, I would like to thank Mrs. E. Ubrich for its precious assistance in library information searches.

REFERENCES

- 1 Breck, D.W., Eversole, W.G., Milton, R.M., Reed, T.B. and Thomas, T.L. (1956) *J. Am. Chem. Soc.*, **78**, 59-63.
- 2 IFP source.
- 3 Laherrère, J. (1998) *Pétrole et Techniques*, **416**, 61-79.
- 4 *Pétrole et Techniques* (1999) **421**, 35-39.
- 5 Jestin-Fleury, N. (1998) *Pétrole et Techniques*, **414**, 37-41.
- 6 Godard, O. (1999) *Pétrole et Techniques*, **421**, 97-99.
- 7 Masseron, J. (1991) *L'Économie des hydrocarbures*, Éditions Technip, Paris.
- 8 Zehnder, S. and Technon, P. (1997) *Pétrole et Techniques*, **406**, 50-54.
- 9 Cosyns, J. and Cameron, C. (1997) *Pétrole et Techniques*, **411**, 77-81.
- 10 Firnhaber, B., Emmrich, G., Ennenbach, F. and Ranke, U. (1999) *Proceedings of the DGMK-Conference, The Future Role of Aromatics in Refining and Petrochemistry*, Erlangen, Germany, 73-97.
- 11 Fournier, G. (1999) *Pétrole et Techniques*, **422**, 62-64.
- 12 *Oil Gas J.* (Dec. 20, 1999).
- 13 *Oil Gas J.* (Dec. 25, 1989).
- 14 *Oil Gas J.* (March 26, 1990).
- 15 *Oil Gas J.* (Dec. 31, 1979).
- 16 *Oil Gas J.* (March 24, 1980).
- 17 Benayoun, D. (1997) *Pétrole et Techniques*, **406**, 55-57.
- 18 Hodges, P. (1999) *Pétrole et Techniques*, **423**, 136-142.
- 19 Seddon, D. (1992) *Catal. Today*, **15**, 1-21.
- 20 Peer, R., Ackelson, D., Genis, O., Shorey, S. and Orchard, N. (1995) *Pétrole et Techniques*, **395**, 58-74.
- 21 Guibet, J.C. and Faure, E. (1997) *Carburants et moteurs, Technologies-Energie-Environnement*, vols. 1 and 2, Éditions Technip, Paris.
- 22 Unzelmann, G.H. (1992) *1992 NPRA Ann. Meet.*, New Orleans (Louisiana), Paper AM-92-05.
- 23 Keesom, W.H., Genis, O., Leubke, C.P. and Marker, T.L. (1992) *1992 NPRA Ann. Meet.*, New Orleans (Louisiana), Paper AM-92-26.
- 24 *Pétrole et Techniques* (1995) **395**, p. 28.
- 25 Heinrich, G., Kasztelan, S. and Kerdraon, L. (1994) In *Setting the Pace with IFP for the 21st Century*, IFP Publication, 143-168.
- 26 Van Leeuwen, K. (1999) *Proceedings of the DGMK-Conference, The Future Roles of Aromatics in Refining and Petrochemistry*, Erlangen, Germany, 7-20.
- 27 Freund, E. (1998) *Pétrole et Techniques*, **414**, 44-51.
- 28 Heinrich, G., Valais, M., Passot, M. and Chapotel, B. (1991) *13th World Petr. Congress*, Buenos Aires, October 20-25.
- 29 Martino, G., Courty, P. and Marcilly, C. (1997) In *Perspectives in Oil Refining, Handbook of Heterogeneous Catalysis*, G Ertl, (Knozinger H, Weitkamp J, Eds), Part B: Catalytic Processes, **4**, 1801-1818, VCH, a Wiley Company.
- 30 Douaud, A. and Girard, C. (1998) *Pétrole et Techniques*, **416**, 7-14.
- 31 Baudoin, C. (1999) *Pétrole et Techniques*, **422**, 94-99.
- 32 Dulout, C. (1999) *Pétrole et Techniques*, **422**, 90-93.

- 33 Swain, E.J. (1992) *Sulphur*, **22**, 16-19.
- 34 Vaquie, J. (1999) *Pétrole et Techniques*, **422**, 100-102.
- 35 Legrand, M. (1999) *Pétrole et Techniques*, **422**, 103-105.
- 36 Kitto, M. (1998) *Sulphur*, **258**, p. 51.
- 37 Facing the Future, *Sulphur* (1998) **258**, p. 43, 45, 49.
- 38 *Rapport n° 25 de l'Académie des sciences française* (1990).
- 39 From Web site of EPA (figures updated Aug. 2000).
- 40 Appert, O. (1999) *Pétrole et Techniques*, **421**, 95-96.
- 41 *Pétrole et Techniques* (1999) **421**, 23-27.
- 42 Petit, M. (1997) *Pétrole et Techniques*, **410**, 67-68.
- 43 Douaud, A. (2000) *Pétrole et Techniques*, **426**, 70-76.
- 44 Lenz, H.P. and Cozzarini, C. (1999) *Emissions and Air Quality*, Warrendale (Pa.), Soc. Automot. Eng.
- 45 Oil Information 2000 (2000) *IEA Statistics*, OECD/IEA, Paris.
- 46 Heinwood, J. and Schafer, A. (1999) *Séminaire TotalFina Changements climatiques, IPIECA*, Paris, May 11-12, in *Pétrole et Techniques*, **421**, 27.
- 47 Moret, M. (1999) *Pétrole et Techniques*, **422**, 68-73.
- 48 Sigaud, J.B. (1999) *Pétrole et Techniques*, **422**, p. 89.
- 49 Sigaud, J.B. (2000) *Congrès SIA 2000*, Lyon (France).
- 50 Vettier, J.P. (2000) *Conference at the CEC-SAE Spring Fuels and Lubricants Meeting*, Paris.
- 51 Belorgeot, C., Boy de la Tour, X. and Chauvel, A. (1994) *Séminaire Vers le 21^e siècle avec les technologies de l'IFP*, IFP, Paris.
- 52 Martino, G. and Marcilly, C. (1997) *Petrofina Chair, Leuven Summerschool on Catalysis*, Brugge, Belgium.
- 53 Cabrera, C.A. (2000) *CatCon 2000*, Houston (TX), USA.
- 54 Maxwell, I.E. (1997) *Cattech*, 5-13.
- 55 Weirauch, W. (2000) *Hydroc. Process.*, **79** (2), 23.
- 56 *Oil Gas J.* (Feb. 28, 2000), p. 53.
- 57 Source CECA.
- 58 Pfenninger, A. (2000) *Proceed. Symp. on Industrial Applications of Zeolites*, October 22-25, Brugge, Belgium, Technol. Instituut vzw, 73-82.
- 59 Coe, C.G. (2000) *Presentation at Symp. on Industrial Applications of Zeolites*, Brugge, Belgium.
- 60 Grandmougin, M.T., Le Bec, R., Plee, D. and Dona, G. (2000) *Proceed. Symp. on Industrial Applications of Zeolites*, October 22-25, Brugge, Belgium, Technol. Instituut vzw, 93-104.
- 61 Schoonover, M.W. and Cohn, M.J. (2000) *Topics in Catal.*, **13** (4), 367-372.
- 62 Marcilly, C.R. (2000) *Topics in Catal.*, **13** (4), 357-366.
- 63 Tanabe, K. and Hölderich, W.F. (1999) *Appl. Catal. A: General*, **181**, 399-434.
- 64 Sheldon, R.A. and Downing, R.S. (1999) *Appl. Catal. A: General*, **189**, 163-183.
- 65 Clerici, M.G. (2000) *Topics in Catal.*, **13** (4), 373-386.
- 66 Hölderich, W. and van Bekkum, H. (1991) In *Introduction to Zeolite Science and Practice*, van Bekkum, H., Flanigen, E.M., and Jansen, J.C. (eds.), Elsevier, Amsterdam, *Stud. Surf. Sci. Catal.*, **58**, p. 631.
- 67 Venuto, P.B. (1997), in *Progress in Zeolite and Microporous Materials*, Chon, H., Ihm, S.K and Uh, Y.S. (eds.), Elsevier, Amsterdam, 811-852.
- 68 Spagnol, M., Gilbert, L., Jacquot, R., Guillot, H., Tirel, P.J. and Le Govic, A.M. (1996) *4th Intern. Symp. Heterog. Catal. and Fine Chemicals*, Basel, Switzerland.
- 69 Ratton, S. (1998) *Chimica Oggi*, 33-37.
- 70 Venuto, P.B. (1994) *Microp. Mater.*, **2**, p. 297.
- 71 Venuto, P.B. and Landis, P.S. (1968), *Adv. Catal.*, **18**, 259-371.
- 72 Coq, B., Gourves, V. and Figueras, F. (1993) *Appl. Catal. A: General*, **100**, 69.
- 73 Moreau, C., Fajula, F., Finiels, A., Razigade, S., Gilbert, L., Jacquot, R. and Spagnol, S. (1998) *Catal. Org. React.*, Dekker, 51.
- 74 Noack, M., Kölch, P., Schäfer, R., Toussaint, P., Caro, J. and Sieber, I. (2000) *Proceed. Symp. on Industrial Applications of Zeolites*, October 22-25, Brugge, Belgium, Technol. Instituut vzw, 25-34.

Final manuscript received in July 2001