



HAL
open science

System Approach Modelling Applied to the Eluxyl Process

D. Pavone, G. Hotier

► **To cite this version:**

D. Pavone, G. Hotier. System Approach Modelling Applied to the Eluxyl Process. Oil & Gas Science and Technology - Revue d'IFP Energies nouvelles, 2000, 55 (4), pp.437-446. 10.2516/ogst:2000032 . hal-02054053

HAL Id: hal-02054053

<https://ifp.hal.science/hal-02054053>

Submitted on 1 Mar 2019

HAL is a multi-disciplinary open access archive for the deposit and dissemination of scientific research documents, whether they are published or not. The documents may come from teaching and research institutions in France or abroad, or from public or private research centers.

L'archive ouverte pluridisciplinaire **HAL**, est destinée au dépôt et à la diffusion de documents scientifiques de niveau recherche, publiés ou non, émanant des établissements d'enseignement et de recherche français ou étrangers, des laboratoires publics ou privés.

System Approach Modelling Applied to the Eluxyl Process

D. Pavone¹ and G. Hotier¹

¹ Institut français du pétrole, 1 et 4, avenue de Bois-Préau, 92852 Rueil-Malmaison Cedex - France
e-mail: didier.pavone@ifp.fr - gerard.hotier@ifp.fr

Résumé — Modélisation du procédé Eluxyl par approche système — Le procédé Eluxyl a pour objectif de séparer le paraxylène des autres xylènes et de l'éthylbenzène. L'Eluxyl utilise la technique du lit mobile simulé qui requiert un réglage particulièrement fin pour obtenir un paraxylène de très haute pureté (supérieure à 99,90 %). Un modèle numérique a été développé simultanément avec la mise au point du procédé. Le but est de faciliter le réglage et d'aider au design, tout en offrant la possibilité d'analyser différentes configurations.

Les objectifs du modèle laissant prévoir de nombreuses évolutions ou modifications du code numérique, le modèle a été développé selon une approche système.

Cet article présente le procédé Eluxyl et le modèle mathématique retenu. Ensuite, la capacité du modèle à prendre en compte les particularités des unités réelles est illustrée par quatre exemples. Dans un premier exemple, nous décrivons comment la dynamique des vannes a été intégrée dans le simulateur. Le but était d'évaluer une durée maximale d'ouverture et de fermeture des vannes qui ne nuirait pas à la qualité du paraxylène produit. Le deuxième exemple illustre la flexibilité de l'approche système par la possibilité de modéliser simplement l'impact d'une vanne retirée pour raison de maintenance.

Le troisième exemple montre comment l'approche système peut aider au design des unités. On expose comment différents designs des chambres de mélange équipant le procédé Eluxyl ont été modélisés et testés. Le point clé est que la sélection des designs a pu être faite par comparaison de leur impact respectif direct sur la qualité du paraxylène produit, et non pas sur des considérations secondaires (minimisation des volumes, etc.).

Finalement, nous montrons comment une fuite de vanne a été modélisée et examinons son impact sur la qualité du paraxylène produit. Cette simulation démontre le haut niveau de spécification requis sur la qualité des vannes.

Tout au long de l'exposé, nous montrons la puissance et l'efficacité de la modélisation par approche système.

Mots-clés : Eluxyl, simulation, modèle, adsorption, paraxylène, séparation.

Abstract — System Approach Modelling Applied to the Eluxyl Process — The Eluxyl process achieves paraxylene separation to other xylenes and ethylbenzene. Eluxyl is a simulated moving bed process that requires a fine tuning to produce paraxylene at a very high level of purity, up to 99.90%. A numerical model has been developed in parallel with the process. Objectives are to help tuning, to help design of additional equipment such as valves and mixing chambers and to test the so-called "what if cases".

According to these objectives, the model is planned to be modified many times in order to test different equipment, to evaluate "what if cases" or even to choose among different configurations. To match these requirements the numerical model has been developed under system approach.

This paper presents the Eluxyl process and its mathematical model. Then, the ability of such a model to represent real units is illustrated through four examples. At first, the paper describes how slow opening and closing valves were modelled. The objective was to evaluate the requirement valves should meet about their time spent before total opening. Secondly, to emphasise the advantage of system approach modelling, the paper presents how a missing (under maintaining) valve could be modelled.

In a third example, it is shown how a system approach model can help the design of real units. This paper explains how the different designs for the mixing chambers that equip the Eluxyl process have been modelled and tested. The key point is that the best design is selected on the simulated resulting performances of the unit—purity and yield.

Finally a “what if case” is presented. Here, a leaking valve is assumed and the net effect on purity and yield shows that requirement about valve leaking should be severe.

All along this paper, we show how system approach modelling is powerful, fast, convenient and almost bug free compared with standard language programming.

Keywords: Eluxyl, simulation, modelling, adsorption, paraxylene, separation.

NOMENCLATURE

SMB Simulated Moving Bed

TMB True Moving Bed

a adsorbed phase in the microporosity

i non-adsorbed phase in the macro- and mesoporosity

b bulk phase

ρ fluid density ($\text{kg} \cdot \text{m}^{-3}$)

Φ molecular sieve porosities

Y fluid volume fractions in the adsorbed phase

X fluid volume fractions in the non-adsorbed phase

X_{inj} volume fractions for injected and produced fluids

f_{inj} flow for injected and produced fluids ($\text{kg} \cdot \text{s}^{-1}$)

δ_{inj} interfaces where fluids are injected or produced (m^{-1})

S bed surface (m^2)

K Fick coefficient for diffusion law ($\text{m}^2 \cdot \text{s}^{-1}$)

t time (s)

\vec{u}_s solid velocity in TMB case ($\text{m} \cdot \text{s}^{-1}$)

\vec{v}_b fluid flow velocity in the bulk phase ($\text{m} \cdot \text{s}^{-1}$)

$f_{i \rightarrow a}$ flow exchange between the macro-mesoporosity (*i*) and the microporosity (*a*) ($\text{kg} \cdot \text{m}^{-3} \cdot \text{s}^{-1}$)

$f_{b \rightarrow i}$ flow exchange between the bulk (*b*) and the macro-mesoporosity (*i*) ($\text{kg} \cdot \text{m}^{-3} \cdot \text{s}^{-1}$)

\vec{J} flow induced by diffusion ($\text{kg} \cdot \text{m}^{-2} \cdot \text{s}^{-1}$)

INTRODUCTION

In a modern approach, mathematical and numerical models are developed along with the chemical reactor or separation unit design. These models are facing different purposes from the most obvious, finding the best tuning, to more technical ones such as model-based advanced control.

In one hand, models are more and more devoted to industrial uses, but, in the other hand, few of them take into account the actual surrounding equipment. In labs, great and

costly efforts are undertaken to enhance knowledge about thermodynamic adsorption laws or chemical reactions. These are essential mathematical laws or equations that feed models, but it would be also essential to model correctly the surrounding equipment such as valves, mixing chambers, etc. Sometimes, surrounding facilities are pretty well modelled and analysed, especially in 3D computed fluid dynamics (CFD). But these models imply time-consuming simulations and design optimisation is performed over external criteria but the unit performance itself. Such criteria could be the best mixing, the shortest time to open a valve or the minimum volume of a pipe. However, it is never obvious how much these criteria are linked to effective performances. The result is that tremendous effort could be engaged to improve equipment regarding an external criterion although it has very little effect on the global unit performances.

Another aspect of modelling concerns the so-called “what if cases”. What would happen if a valve leaks? What would happen if a pump reacts with a delay? What would happen if a valve has to be removed one hour for maintaining? “What if cases” generally deal with surrounding equipment rather than catalyst or molecular sieve.

This is the reason why we consider that modelling should not only involve the catalyst (the molecular sieve) but also the equipment. In addition, we consider that such a modelling should not be entirely coded in common language (like Fortran or C) but should be encapsulated in a global software that allows easy modifications and that guaranties free-of-bug modelling.

We present hereafter how real slow opening and closing valves have been modelled and their impact on the unit performances. Then, we explain how we modelled the 96 mixing chambers required for the Eluxyl process and how we selected the best design, once again, regarding the net performances. Finally, a “what if case” is presented about the occurrence of a leaking valve.

1 ELUXYL PROCESS PRESENTATION

1.1 Large Scale Industrial Continuous Liquid Chromatography

The major parts of industrial separations (80%) are distillation processes. Nevertheless, there are some cases where distillation is either technically not feasible or uneconomical as compared to crystallisation membranes or adsorption.

In the case of paraxylene (Px) separation from the other C₈ aromatic isomers ethylbenzene (Eb) orthoxylene (Ox) and especially metaxylene (Mx) for which the difference in boiling point is less than 1°C, crystallisation and adsorption are employed.

Nowadays adsorption processes are always chosen for economical reasons.

Adsorption processes are generally batch processes: a fluid containing an impurity to be removed is contacted with a solid that adsorbs a specific component. When the adsorption capacity is saturated, the impurity breaks through, and the solid has to be regenerated for the next cycle. In the refining and petrochemical industries continuous processes are by far preferred to batch ones essentially because of the very large quantities processed.

Countercurrent and simulated countercurrent adsorption or chromatography are particular ways to make this operation continuous.

In countercurrent adsorption the adsorbing solid, the "sorber", circulates in the opposite direction by reference to the fluid. Three zones are actually necessary, but in most cases four are found.

The fluids to be handled are a mixture of two components A (the most adsorbed) and B (the least adsorbed) and a vector fluid or desorbent D or solvent (either neutral or adsorbed). A and B have to be separated.

The solid is injected at the top of a column, it moves downward. The fluids move upward. The mixture to be separated is injected in the middle of the column. Component A (the adsorbed one) is withdrawn from the fluid phase by the solid. After a certain length of contact all A has been removed from the fluid phase and the major part of this fluid phase can be removed from the process in what is known as the raffinate. At this point the fluid phase contains B and D.

When the fluid is further contacted with the solid, B is adsorbed from the fluid phase. After a certain contact length all B has been removed from the fluid phase and pure desorbent D can be recycled to the bottom of the column. Below the feed injection point the solid containing A (mostly) and B is swept by the desorbent. After a certain contact length all of B has been removed from the solid and as a consequence from the fluid phase in equilibrium with it. Thus, a fluid phase containing A and D is removed from the process: this is the extract. As the solid moves further downward, the desorbent finishes to remove A from the solid, and at the bottom of the column the solid is completely regenerated. It can then be recycled to the top of the column.

In this system there are four zones delimited by the fixed injection and withdrawal points, from bottom to top:

- 1 between desorbent injection and extract withdrawal A is desorbed;
- 2 between extract withdrawal and feed injection B is desorbed;
- 3 between feed injection and raffinate withdrawal A is adsorbed;
- 4 between raffinate withdrawal and desorbent injection B is adsorbed.

While the solid speed is constant throughout the four zones because of equipment balance, the fluid phase shows four different velocities.

The process parameters are those five velocities, and a particular fixed concentration profile is associated to each field of velocity.

Actually, from a technological standpoint, it is difficult to displace the solid at a constant speed and to avoid solid attrition. If the column is cut into a sufficient number of fixed beds the beds rather than the solid can be displaced by small discrete moves. Of course this implies that between each two beds it is possible to inject desorbent or feed and to remove extract and raffinate.

In this case the process parameters are the four internal fluid velocities and the frequency at which the beds are permuted. One can consider the beds as a series connected in a closed loop. The concentration profile is translated at a constant velocity and the solid is fixed.

Another particular point is that Zone 4, which was not strictly necessary in the true moving bed (TMB) process, becomes very useful in the simulated moving bed (SMB). The dead volume of each bed has to be displaced by the fluid phase in order to be equivalent to a zero velocity in the TMB system. Zone 4 acts as a powerful desorbent economiser: it may reduce desorbent consumption by a factor 3.

1.2 Model Description

This section is devoted to the flow equations that describe the model. Other mathematical models can be found in [1-6].

Three phases are assumed to take place in a bed: the *bulk* (*b*), or bed porosity, between the molecular sieve pellets, the *internal phase* (*i*) or pellet porosity, but not adsorbed in the molecular cage, and the *adsorbed phase* (*a*) in the molecular cage. In the bulk, the flow equations are standard including convection and longitudinal diffusion. The equations below describe the model we are using in both configurations: simulated countercurrent (whenever injections are switched every switching time and solid velocity u_s is zero) and true countercurrent (whenever injections remain at the same place and solid velocity u_s is negative):

$$\frac{\partial(\rho_a \Phi_a Y)}{\partial t} + \vec{\nabla} \cdot (\rho_a \Phi_a Y \vec{u}_s) = f_{i \rightarrow a} \quad (1)$$

$$\frac{\partial(\rho_i \Phi_i X_i)}{\partial t} + \vec{\nabla} \cdot (\rho_i \Phi_i X_i \vec{u}_s) = -f_{i \rightarrow a} + f_{b \rightarrow i} \quad (2)$$

$$\frac{\partial(\rho_b \Phi_b X_b)}{\partial t} + \vec{\nabla} \cdot (\vec{J} + \rho_b \Phi_b X_b \vec{v}_b) = -f_{b \rightarrow i} + X_{inj} \frac{f_{inj} \delta_{inj}}{S} \quad (3)$$

These mathematical formulas are standard equations excepted for the injections and withdrawals. In general reactor, model injections and withdrawals are modelled as boundary conditions. Here, they are located within the molecular sieve. We assume that they take place on a single interface, infinitely small, that we model with a Dirac δ_{inj} .

The diffusion in the bulk is assumed to follow the Fick law, where K is a coefficient that can depend on the local fluid velocity (v_b):

$$\vec{J} = -\rho_b \Phi_b K \vec{\nabla} X_b \quad (4)$$

Because we have mainly xylenes and paradiethylbenzene (PDEB), we assume as well that all components have the same density:

$$\rho_b = \rho_i = \rho_a = \rho \quad (5)$$

We also assume that the exchange between the bulk (b) and the internal but not adsorbed phase (i) is so fast that both compositions are the same:

$$X_i = X_e = X \quad (6)$$

Finally, we eliminate the last unknown flux $f_{i \rightarrow a}$ between the internal but not adsorbed phase and the adsorbed phase assuming that the equilibrium is always achieved and that there is a relationship (f) between the internal composition (X) and the adsorbed composition (Y). For example, f can be Langmuir-Freunlich. Of course, different f can be used according to the chosen thermodynamics. The assumptions imply that for mass balance between the different phases, whenever one mole of a component is adsorbed, another mole of another component is desorbed. The solid is constantly saturated. The number of molecules adsorbed per volume unit of crystal is constant whatever the composition of the adsorbate:

$$Y = f(X) \quad (7)$$

Summing up Equations (1), (2) and (3) leads to the following unique equation:

$$\begin{aligned} & \frac{\partial(\rho(\Phi_b + \Phi_i)X + \rho\Phi_a Y)}{\partial t} \\ & + \vec{\nabla} \cdot (\vec{J} + X\rho(\Phi_b \vec{v}_b + \Phi_i \vec{u}_s) + \rho\Phi_a Y \vec{u}_s) = X_{inj} \frac{f_{inj} \delta_{inj}}{S} \end{aligned} \quad (8)$$

1.3 A Typical Dynamic Simulation

We present here a typical simulation performed on a hypothetical unit of 1 m² of internal surface. Because a high purity of 99.80% is required together with a high yield of 97.00%, the unit is designed with 24 beds filled with 1.2 m height of molecular sieve. The different flow rates and their places of injections or withdrawals are chosen to reach the required performances. Figure 1 shows the composition profiles in this SMB simulation. Profiles are presented at every switching time. Due to the displacement of the feed injection location and to the pumparound we observe that the profiles are rotating around the adsorbers. In addition, if we compare the last two sets of profiles, we can observe that they are still increasing, but that they seem to reach some kind of steady state.

Obviously, it is difficult to analyse such a graph. This is why the way we present the Eluxyl profiles is slightly modified. The profiles are plotted as if the observer were moving along the unit with the eluant injection point. As a result, in Figure 2 the profiles seem to be more fixed. Thanks to such a presentation, we can observe that the meta- and orthoxylenes (in green) are moving rightward and that the paraxylene (in red) is moving leftward, toward the extract. In fact, they begin to separate.

For the observer, the eluant is always injected in Bed 1, the feed in Bed 16 and extract is always produced between Beds 4 and 5 while raffinate is always produced between Beds 21 and 22, although each of them is moving one bed rightward at every switching time.

After a certain process time (let say 50 h), the profiles reach a pseudo-steady state. Such profiles are presented in Figure 3. Paraxylene and meta-orthoxylenes are very well separated and we can observe on the zoom at right that meta-orthoxylenes and ethylbenzene are almost null in front of the extract (Bed 5). This leads to a very high purity of 99.90%. By the same time, the paraxylene in front of the raffinate is rather low (0.3%) and a 97.6% yield can be reached.

2 REAL UNIT MODELLING

The objective is to develop a numerical simulator of the SMB Eluxyl process which is as close as possible to actual units. The simulator should help tune units, test the real effect of new technological improvement and evaluate the “what if cases”. Hence, the model should not be too simple to be accurate and reliable, either in flow description, thermodynamic adsorption or surrounding equipment.

The model we developed is twofold:

- flow equation and molecular sieve behaviour that have already been presented;
- valve, mixing chambers and the surrounding equipment.

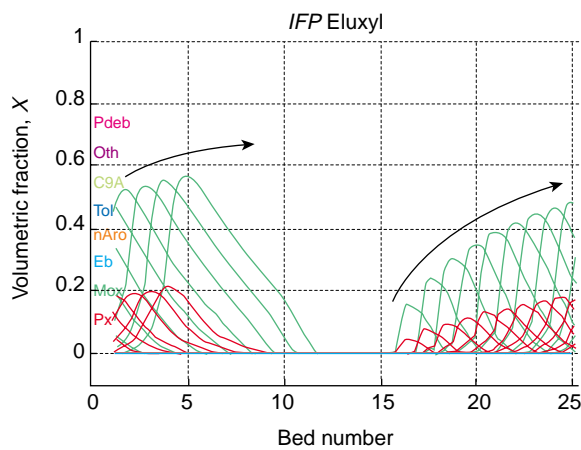

Figure 1
Example of Eluxyl SMB simulation.

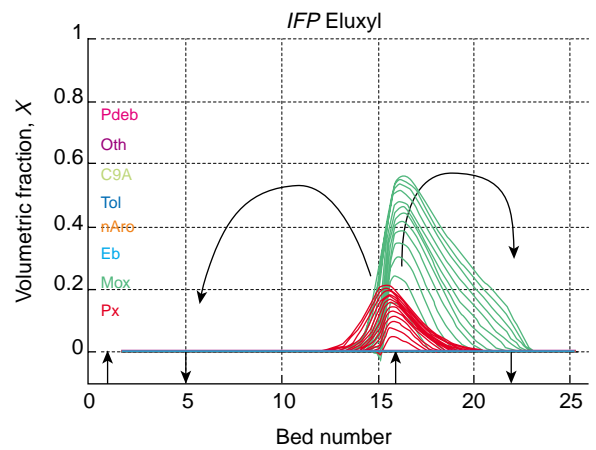

Figure 2
Example of Eluxyl SMB simulation presented as for a TMB process.

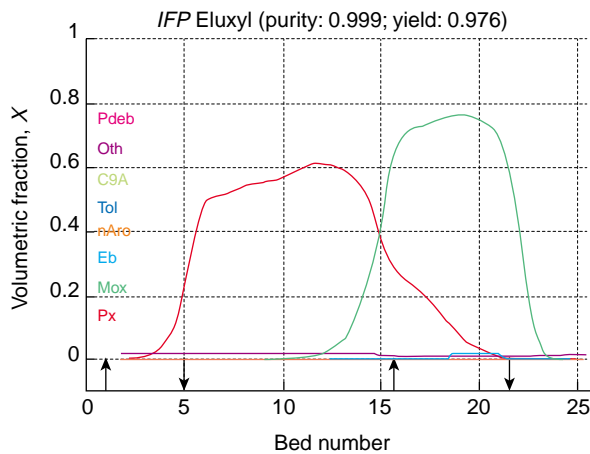
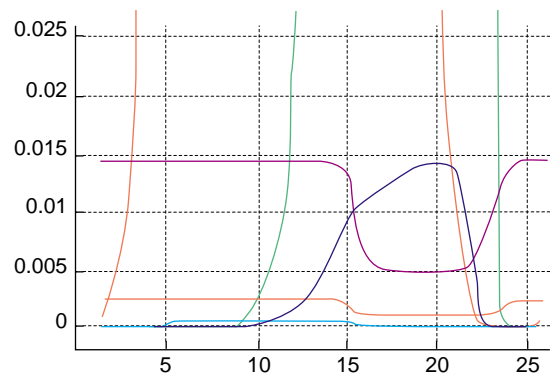

Figure 3
Eluxyl SMB simulation at steady state (zoom at right).



This section is devoted to the second item that makes the model representative of the real process.

There are two different ways to model the SMB Eluxyl process. The simplest one is to approximate the process by a TMB process. The main advantage is that we simulate a constant moving bed instead of the discontinuous switching valves in the SMB. As a result, the model can reach a steady state, which simplifies modelling, reduces computation time and helps analyse.

However, this has disadvantages. First, we are not sure that performances derived from TMB are the same as the ones derived from a SMB model. Secondly, this prevents from analysing improvements such as mixing chamber optimisation and real process misfunctions such as leaking valves or “what if cases”.

Four examples are presented to give an insight into system approach modelling:

- reality modelling: ideal instantaneous to real slow opening valve;
- reality modelling: valve maintenance;
- design optimisation: mixing chamber modelling;
- “what if case”: what if one valve leaks.

2.1 Reality Modelling: Ideal Instantaneous to Real Slow Opening Valve

This problem is rather important for Eluxyl, which involves at least 96 valves that are opened almost every half an hour for about 80 s and closed. This means that each of the 96 valves is opened and closed more than 16 000 times each year.

2.1.1 Model of Ideal Valve Cyclic Switching

To be close to reality, the model solves a SMB process. This implies that the valves injecting the fluids (feed and desorbent) and the valves withdrawing the product flows (raffinate and extract) are switched forward at every switching time. In fact, this is a key point for *IFP* Eluxyl process which takes advantage of injection and production through individual valves rather than a rotary valve that imposes the same sequence for all of them. For example, the opening and shut down of each valve can be adapted for each valve, in connection with local conditions. This gives a very interesting adaptability, especially for configuration changing or valve skipping for maintenance.

For standard modelling, these valves are supposed to be ideal and can be opened and closed instantaneously (*Fig. 4*). In such a case, simulation of *Figure 3* shows that high purity and yield can be achieved.

However, real valves are slow and need time to open and close. The question can be arisen whether to know to which extent the valve can take some time to be opened or closed. In fact, a valve is opened for about 80 s during a cycle. Is it necessary to have powerful valves that may be opened in one or two seconds or may valves spend few seconds to be completely opened without reducing Eluxyl performances? To answer that question, slow valves have been modelled.

2.1.2 Slow Valve Modelling

Slow valves have been introduced to be closer to real valves than the ideal instantaneous ones already used in *Figure 4*. The model of a slow valve is presented in *Figure 5*. It corresponds to a first order transfer function and the same transfer function is assumed to hold true for opening and closing.

It can be noticed that now two valves can be partly opened at the same time, which is different from the previous ideal case.

The modelling of such valves is quite simple whenever we use the “system approach”. At the valve level, the model is made of the block diagrams as presented in *Figure 6*. The flow dispatcher block includes an *IFP*-made C program that dispatches the continuous flows to piecewise squared flows

towards each bed (as in *Figure 4*). In *Figure 7*, the squared signals are smoothed (filtered) by the transfer function before inputting the beds.

As it can be seen, this way of modelling is very powerful and safe. The user only needs to tune the transfer function parameters (find *a* and *b*), cut 24 links (wires) for feed and 24 links (wires) for eluant, copy 2×24 transfer functions and connect them to the “demux” and the downstream blocks.

The results of this study were very satisfactory. Of course, the time the valves can take to open and close depends on the required level of purity, but it was found that this time is two to three times greater than the one that would have been expected before the simulations.

2.2 Reality Modelling: Valve Maintenance

Model Diagram at the Bed Level: a Close Unit Representation

We want here to emphasise a different point of view between modelling with standard language and system approach. For example, modelling 24 beds in a standard language would involve a loop that solves 24 times the same set of equations. This is certainly very convenient from a computational point of view, but could be a disadvantage to match real units, especially because real units never have exactly 24 identical beds (*Fig. 8*). For example, a real bed could have a valve removed for maintenance and fluids diverted to previous and next beds (*Fig. 9*). Such a case could be easily and safely modelled in system approach where each bed is individually built (*Fig. 8*). Model modifications are presented in *Figure 9*. Of course it could be done as well in a Fortran “do loop” but with greater difficulties and certainly less safely. In addition, it is straightforward. This is a true advantage for transferability between engineers.

Of course, system approach is very convenient but does not prevent from writing some piece of code (here in C) to calculate exactly what is happening at the molecular sieve level. But such codes are very well localised and do not interact with the higher levels such as those presented in *Figures 6-9*.

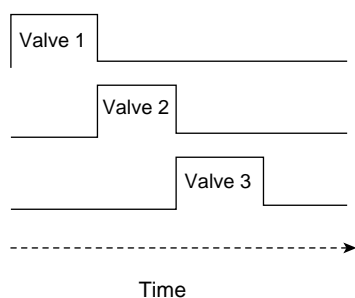

Figure 4

Flow rate through ideal valves *versus* time.

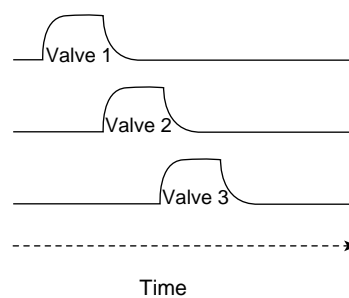

Figure 5

Flow rate through slow valves *versus* time.

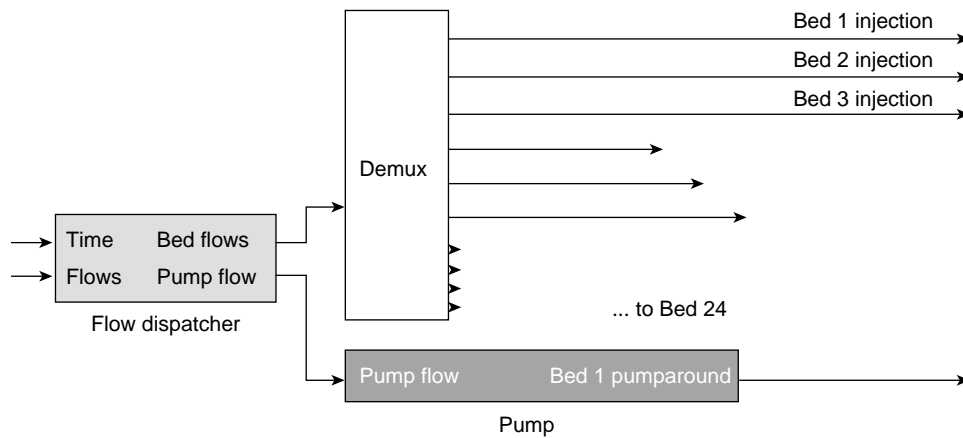

Figure 6
Model diagram at the ideal valve level.

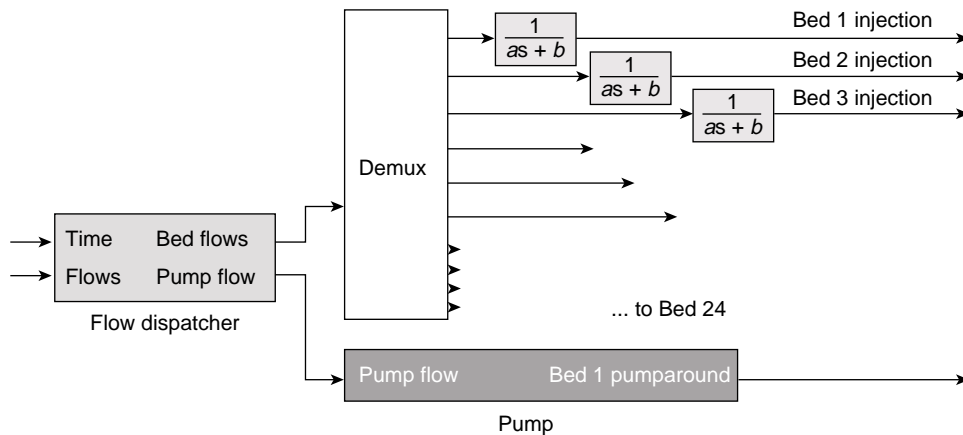

Figure 7
Model diagram including transfer function to model slow valves.

2.3 Design Optimisation: Mixing Chamber Modelling

2.3.1 Why Mixing Chambers

Mixing chambers are used to mix the injected fluids (the feed and the eluant) to the pumparound. The objective is to achieve a rapid and homogeneous mixing all over the surface and to guarantee that the chambers are flushed rapidly by the pumparound after the injection to avoid residual impurities.

2.3.2 Mixing Chamber Modelling

The objective here is to use simulation to help design mixing chambers. In fact, the best possible design should be judged on the Eluxyl process performances themselves (purity and

yield) and not judged on *a priori* criteria such as minimum volume or minimum pressure drop.

According to technical constraints, many different designs have been suggested. Each of them has been studied in CFD by the IFP CFD team and a transfer function that characterised the flow through the mixing chambers has been derived for each.

A reduced model of the mixing chambers giving almost the same transfer function has then been placed in the simulator in front of each plate (Fig. 10). Reduced models simulate the same volume as CFD, but with less meshes. The number of meshes, their volume, the numerical space scheme that solves the reduced model are chosen so as to obtain the same transfer function as for CFD. Hence, reduced models

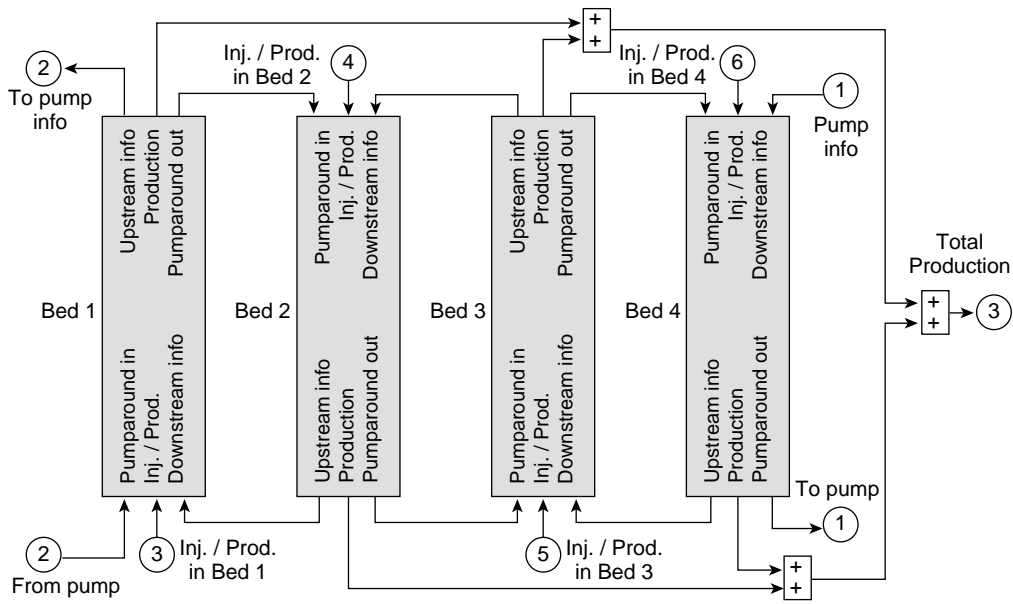

Figure 8
Model diagram at the bed level (only 4 beds instead of 24 for simplicity).

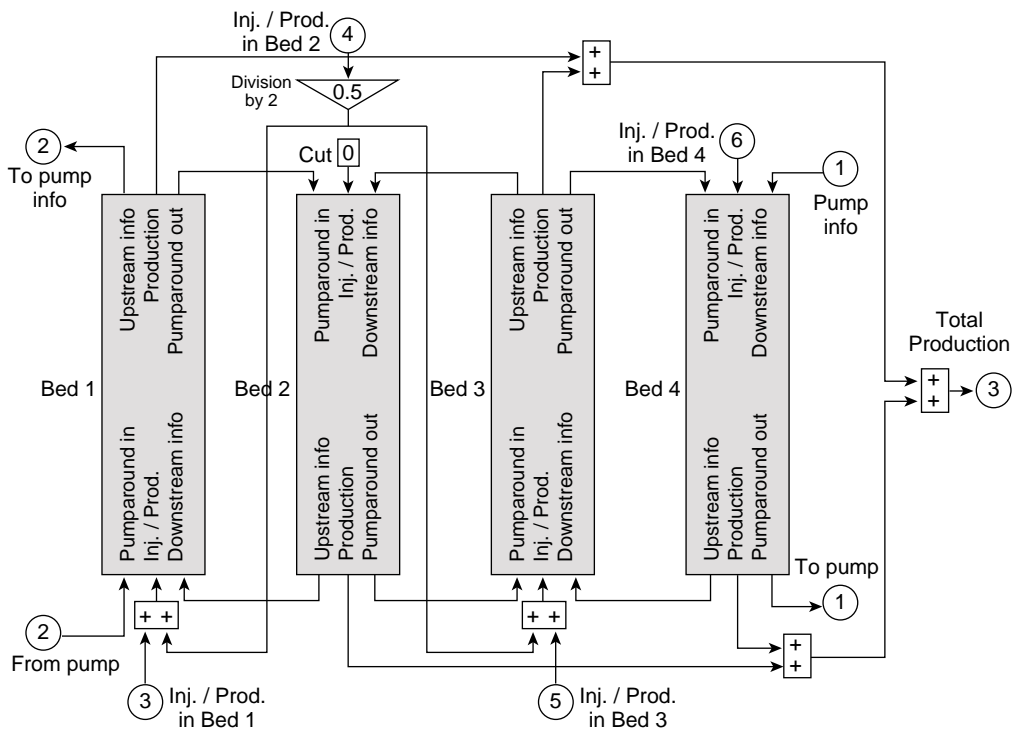

Figure 9
Same as Figure 8 but injection in Bed 2 is diverted equally to previous and next beds.

are not transfer functions. Transfer functions are just used for validation.

Actually, reduced models have been used because one CFD simulation for one mixing chamber is time-consuming and Eluxyl process includes up to 96 such chambers. Each design has been simulated and evaluated directly on its impact on the Eluxyl performances. This gave rise to the selection of the best one, *i.e.* the one that gives rise to the best performances.

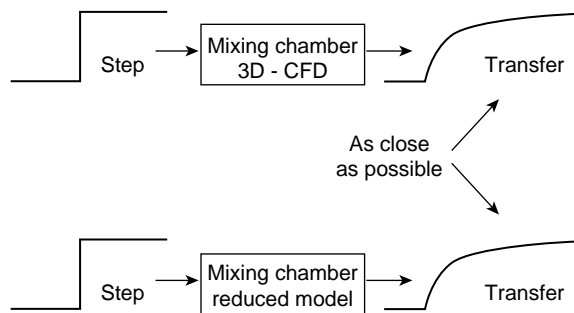

Figure 10
Mixing chamber reduced model to fit Eluxyl model.

2.4 “What if Case”: What if One Valve Leaks

In its high-purity version, Eluxyl unit is made of two adsorber towers divided in 12 beds each. Each of the four flows (desorbent, feed, extract and raffinate) should be injected sequentially in these 24 beds. This means that an Eluxyl unit uses 24*4 valves. At every switching time—let say about every 80 s—four valves are closed and four are opened. Each valve is opened and closed every 24 switching times—about every 30 min in our example—and should run for years.

Although the selected valves can stand many openings and closings, we can wonder what would happen if one valve begins to leak.

Once again, modelling is quite simple and bug free: just add an extra injection of feed in one bed. Then different simulations with different leak flow rates have been run. The results are presented in Figure 11 where it can be seen that performances are very sensitive to leaking.

According to simulations, valve specifications on opening and closing time are not as strong as expected, but valve specifications about leaking should be severe.

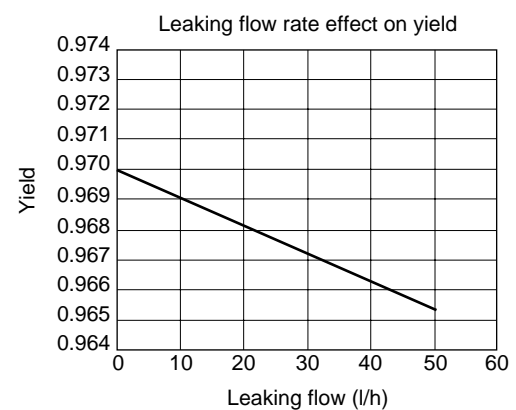
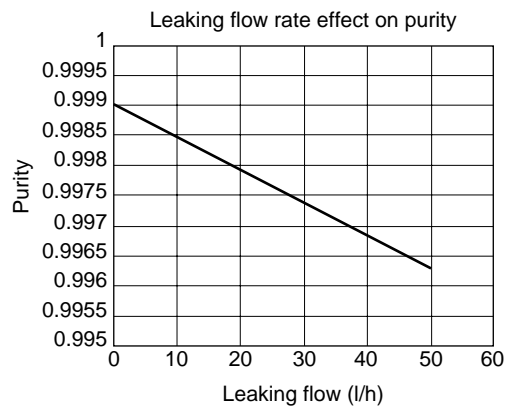

Figure 11
Leak flow rate effect on the decrease of purity and yield.

CONCLUSION

A numerical model has been developed along with the Eluxyl process. Objectives were to help tune, to help design of additional equipment such as valves and mixing chambers and to test the so-called “what if cases”.

According to these objectives, the model was planned to be modified many times in order to test different equipment, to evaluate “what if cases” or even to choose among different configurations. To match this requirement the numerical model has been developed under system approach.

Four different examples illustrate how the system approach model is able to simulate real units. To model real units, real slow valves were taken into account. Even a missing valve under maintenance was modelled. Mixing chambers best design selection is presented as well. The optimisations were performed considering the unit plus the mixing chambers, not only the mixing chambers. As a result, optimisation criteria were product purity and yield. Finally, a “what if case” about a leaking valve is given.

All along this paper, we show why system approach modelling is powerful, fast, convenient and almost bug free compared to standard language programming.

System approach allows modelling all surrounding equipment without great difficulties. Moreover, it allows easy equipment exchange and test.

Because units are made of molecular sieve (or catalyst), fluids, equipment and also advanced control, numerical model should include molecular sieve equations and fluid thermodynamic equations but also equipment and, if necessary, advanced control algorithm.

REFERENCES

- 1 Hassan, M.M., Shamsur Rahman, A.K.M. and Loughlin, K.F. (1995) Modelling of Simulated Moving Bed Adsorption System: A More Precise Approach. *Separation Technology*, **5**, 77-89.
- 2 Ching, C.B., Chu, K.H., Hidajat, K. and Uddin, M.S. (1991) Experimental and Modeling Studies on the Transient Behavior of a Simulated Countercurrent Adsorber. *Journal of Chemical Engineering of Japan*, **24**, 5, 614-621.
- 3 Ray, K.R. and Carr, R.W. (1995) Numerical Simulation of a Simulated Countercurrent Moving Bed Chromatographic Reactor. *Chemical Engineering Science*, **50**, 19, 3033-3041.
- 4 Ray, K.R., Carr, R.W. and Rutherford, A. (1994) The Simulated Countercurrent Moving Bed Chromatographic Reactor: A Novel Reactor-Separator. *Chemical Engineering Science*, **49**, 4, 469-480.
- 5 Ruthven, D.M. and Ching, C.B. (1989) Counter-Current and Simulated Counter-Current Adsorption Separation Processes. *Chemical Engineering Science*, **44**, 5, 1011-1038.
- 6 Balanec, B. (1992) Modélisation de la technique de séparation par adsorption en contre-courant simulé. Application à la séparation du paraxylène de la coupe C₈ aromatique. *Thesis*, université Pierre et Marie Curie, Paris.

Final manuscript received in January 2000