



HAL
open science

Energy Procedia The DMXTM process: an original solution for lowering the cost of post-combustion carbon capture

Ludovic Raynal, Pascal Alix, Pierre-Antoine Bouillon, Adrien Gomez, Marie Le Febvre de Nailly, Marc Jacquin, Jean Kittel, Angella Di Lella, Pascal Mougouin, Jean Trapy

► To cite this version:

Ludovic Raynal, Pascal Alix, Pierre-Antoine Bouillon, Adrien Gomez, Marie Le Febvre de Nailly, et al.. Energy Procedia The DMXTM process: an original solution for lowering the cost of post-combustion carbon capture. Energy Procedia, 2011, 4, pp.779-786. 10.1016/j.egypro.2011.01.119 . hal-02420557

HAL Id: hal-02420557

<https://ifp.hal.science/hal-02420557v1>

Submitted on 20 Dec 2019

HAL is a multi-disciplinary open access archive for the deposit and dissemination of scientific research documents, whether they are published or not. The documents may come from teaching and research institutions in France or abroad, or from public or private research centers.

L'archive ouverte pluridisciplinaire **HAL**, est destinée au dépôt et à la diffusion de documents scientifiques de niveau recherche, publiés ou non, émanant des établissements d'enseignement et de recherche français ou étrangers, des laboratoires publics ou privés.



Distributed under a Creative Commons Attribution - NonCommercial - NoDerivatives 4.0 International License



ELSEVIER

Available online at www.sciencedirect.com



Energy Procedia 4 (2011) 779–786

**Energy
Procedia**

www.elsevier.com/locate/procedia

GHGT-10

The DMXTM process : an original solution for lowering the cost of post-combustion carbon capture

Ludovic Raynal^a*, Pascal Alix^a, Pierre-Antoine Bouillon^a, Adrien Gomez^a, Marie le Febvre de Nailly^a, Marc Jacquin^a, Jean Kittel^a, Angella di Lella^b, Pascal Mougin^b and Jean Trapy^b

^aIFP Energies nouvelles, Rond point de l'échangeur de Solaize, BP3, 69360 Solaize, France

^bIFP Energies nouvelles, 1-4 avenue de Bois Préau, 92852 Rueil-Malmaison, France

Abstract

To make the deployment of carbon capture possible, it is highly needed to develop original solutions that induce low energy penalty and that are easy to operate. This paper aims at presenting the DMXTM process developed at IFP Energies nouvelles based on special solvents which are characterized by the formation of two immiscible phases for given temperature and CO₂ loading conditions. The concept of demixtion is briefly described in terms of physico-chemical properties, its interest and all required steps for appropriate process development are discussed. The corresponding process is presented and a technico-economic analysis is given. It is shown than one can reach a reboiler duty as low as 2.1 GJ/t CO₂ which is significantly lower than the 3.7 GJ/t CO₂ of the 30wt.% MEA reference process. It is also discussed that the energy consumption at reboiler cannot be the only parameter to consider for comparison with other processes and some further information about the DMXTM process are given. Operational issues are particularly discussed. In that sense, the performances of the DMX-1TM solvent in terms of degradation and corrosion are shown. Similarly a particular focus is made on the liquid/liquid separation which is a key aspect of the DMXTM process.

© 2011 Published by Elsevier Ltd. Open access under [CC BY-NC-ND](https://creativecommons.org/licenses/by-nc-nd/4.0/) license.

Keywords: CO₂ capture ; solvents ; process evaluation ; cost analysis

1. Introduction

It is widely accepted that Carbon Capture and Storage is one among the different solutions for decreasing greenhouse gases emissions. According to the recent IEA report [1], CCS may represent up to 20% of CO₂ mitigation in 2050. To make the deployment of CCS possible and thus reach this ambitious objective, it is highly needed to develop original solutions in terms of CO₂ capture. IEA considers four main actions and milestones for the development of new processes : the scalability and the capital costs, the stream composition influence, the energy penalty and the process integration. All these drivers have been taken into account in the development of the

* Corresponding author. Tel.: +33 (0)4.78.02.25.27; fax: +33 (0)4.78.02.20.08

E-mail address: Ludovic.Raynal@ifpenergiesnouvelles.fr

DMX™ process and are discussed in the present paper. The main driver is the energy penalty. It is indeed well known that "first generation" MEA based post-combustion carbon capture process requires high energy consumption, the big part of it corresponding to the heat consumption at the regeneration step. It is then common to compare solvents in terms of thermal energy requirements, the baseline being 3.7 GJ/tCO₂. Increasing the MEA concentration is a first way towards energy penalty reduction, however this must be done taken into account operational issues that are corrosion, amines degradation and associated emissions. IFP Energies nouvelles has developed the HiCapt+™ process in that sense [2] in order to be able to propose an efficient process for short term deployment. Using original or blends of amines is a second way towards energy consumption reduction, and several important research programs have been set in that perspective [3-5]. However, if one expects significant cost reductions, it is believed that one should also develop breakthrough solutions, called "second generation" processes for mid term and long term deployment. A very original solution, the DMX™ process, taking advantage of phase separation of the solvent, has been developed by IFP Energies nouvelles in the last few years. The present paper describes this process in details and the latest results obtained with these original solvents. A particular focus is made about the DMX™ concept itself and associated thermodynamic properties which make it a very competitive process in terms of energy consumption, and about operational issues, such as liquid/liquid separation, degradation or corrosion, which make it a viable process for industrial application.

2. Objectives for a new efficient post-combustion capture process

2.1. Analysis of the MEA process

Post-combustion capture, PCC, is believed to be a good answer for CO₂ capture on industrial flue gases. The CASTOR EU project has shown that gas treatment processes based on the use of chemical solvents indeed meet the requirements of 90% recovery of CO₂ from flue gas while delivering a high purity CO₂ for storage. However, the reference case, being the 30wt.% MEA process, is known to be very demanding in terms of energy consumption. Indeed, about 3.7 GJ/ton_CO₂ are required for solvent regeneration [5,6]. However it is not the only cost. As shown in [7], the energy penalty cost represents about 60% of the total CO₂ avoided costs for the 30wt.% MEA process, the operational and capital costs representing about 70% and 30% respectively.

2.2. Objectives and required steps for a new process

It is commonly accepted that the objective for the development of a new process is, for given boundary conditions (flue gas composition, CO₂ capture rate, purity of CO₂, emissions/waste), first to make sure that the energy consumption would be reduced and second that there would be no or little added capital costs, a reduction being looked for. In that sense, we can conclude that a good solvent must be characterized by :

- 1.1. a high cyclic capacity, that is by having high mol/kg loadings,
- 1.2. a low reaction energy,
- 1.3. a low stripping energy,

all latter properties being given by thermodynamic Vapor-Liquid Equilibrium data, mainly influencing the energy consumption but also influencing the design of equipments via the solvent flow rate,

- 2. a fast kinetic to ensure that packed columns (absorber and stripper) are of acceptable size.

Operational issues are less discussed, however they could be considered as priority number one. When developing a new process, one should make sure that what is developed at laboratory scale will satisfy industrial requirements. Indeed, a said "very efficient" process would not be deployed if it generates corrosion and consequently requires high cost high quality materials, or if it comes with solvent degradation that further induces solvent consumption and eventually unwanted emissions. We can thus add the following requirements :

- 3. a low degradation (thermal and reactive degradation),
- 4. an easy operation (small washing section, no foaming or corrosion).

Taking into account these objectives and wishing to propose a breakthrough solution, IFP Energies nouvelles has been developing for the last few years the DMX™ process [7-9]. This process, which is based upon liquid/liquid separation, is described in the following section. A first paragraph is dedicated to a general description of the

process, results are discussed in the second paragraph. The latter are focusing on two aspects, thermodynamic data which enable energy consumption calculations and operational issues which make the process viable for industrial application.

3. The DMX process

3.1. Concept

Amines are commonly used for chemical absorption of acid gas, mainly in the field of natural gas sweetening, and now in carbon dioxide post-combustion capture. Originally, alkanolamines have been preferred for several reasons. First of all, an alcohol group reduces drastically the vapor pressure of the amine, which guarantees no contamination of the treated gas by the amine. Second, alcohol groups allow to tune the basicity of the amine, and thus its reactivity, in order to be in adequation with the acidity of the gas. Finally, an alcohol group increases the solubility of the amine in water, and keeps the dielectric constant of the solvent high, even at high amine concentration. Indeed, a high amine solubility and a high dielectric constant are two important features in order to avoid any liquid-liquid phase separation or precipitation, when a high amount of salt is produced by reaction of the amine and the acid gas. Rather than taking liquid-liquid phase separation or precipitation as a drawback, it could be seen as a very good opportunity to reduce the cost of carbon dioxide capture. In this work, we focus on a solvent that exhibits a liquid-liquid phase separation, that is from the industrial point of view easier to handle than a liquid-solid separation. Composition of the two liquid phases depends of various parameters like amine concentration in the solvent, carbon dioxide partial pressure or temperature. In the present DMX™ process, after the heat cross exchanger (see section 3.3), between the absorber and the stripper, we can obtain a water rich phase, with a very high carbon dioxide loading and an amine rich phase, with a very low carbon dioxide loading. Actually, this last phase does not need to go through the stripper, as its loading is very low. Then, separation of the phases allows us to reduce the liquid flow rate in the stripper, and thus the energy requirement for the regeneration of the solvent. Several solvents have been studied at IFP Energies nouvelles, in the present paper we focus on the so-called DMX-1 solvent which shows impressive capacity of absorption of carbon dioxide, very good stability towards potential degradation, low corrosion, and fast separation of the two phases. These latter characteristics are discussed in the following section.

3.2. Results

3.2.1. Thermodynamic data

To simulate the absorption process, many fluid properties are needed and in this work, we focus on two of them: phase equilibrium and heat of absorption. The main data are the liquid – vapor between CO₂ and the DMX-1 solvent; this kind of data has been performed in equilibrium cell using the static method [10-11]. Precisely known quantities of solvent and carbon dioxide have been introduced inside an equilibrium cell and its temperature and pressure in equilibrium conditions have been recorded. The partial pressure of carbon dioxide and the overall composition of the liquid phase have been deduced from mass and volume balances. These measurements give also access to the bubble pressure of the solvent. Figure 1 shows such results with the partial pressure of CO₂ as a function of the liquid composition expressed in mol of CO₂ by mass of solvent for a temperature of 313.15 K. We have also added some results of the literature about the water + MEA + CO₂ system at the same temperature [12-13]. The DMX-1 solvent shows a significantly different behaviour from the MEA solvent. It can be seen that the DMX-1 solvent shows a much better cyclic capacity than the aqueous solution of MEA for pressure varying from 0.001 close to 0.01 MPa which are the pressure range of the flue gas at outlet and inlet of the absorption section respectively. The difference in shape for both isotherms has also a strong impact on the stripping of CO₂. With DMX-1 solvent, a lower stripping is required for solvent regeneration compared to MEA solutions. This result has a direct impact on the heat of regeneration of the solvent.

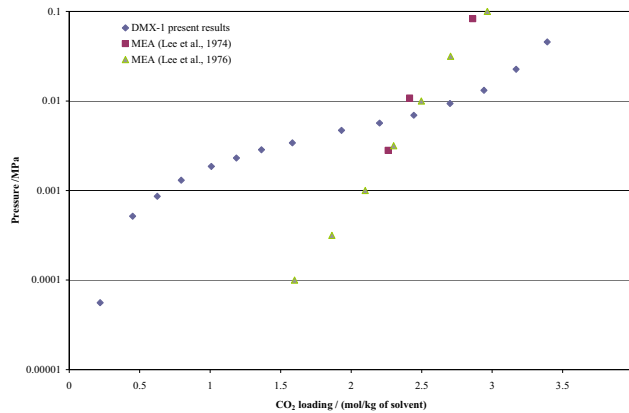

Figure 1 : Isotherms of absorption of CO₂ in DMX-1 and MEA solvent at 313.15 K.

The data have been modeled with a semi-empirical approach coupling i) the mass action law of the chemical reactions, ii) the mass balances of the compounds, iii) the electro-neutrality of the solution and iv) the Henry law for the phase equilibrium. The heat of absorption of CO₂ into the solvent is directly deduced from this model using the van't Hoff law [14]. The calculated heat of absorption is close to -60 kJ.mol^{-1} for the considered temperature range as compared to -85 kJ.mol^{-1} obtained for CO₂ - MEA system. For the liquid – liquid equilibrium, measurements have been performed in a transparent cell where both liquid phases are sampled [15]. Each of them has then been analyzed by acid and volumetric titrations in order to access to the amine and CO₂ contents. This information has been directly used in the simulator to calculate the liquid phases split and to further determine the flow that will be sent at regeneration step. From these four pieces of information, high cyclic capacity, low stripping energy, low heat of absorption, only a proportion of the fluid towards the regeneration step, one can expect important energy savings. Volumetric properties such as density and viscosity have also been determined for different CO₂ loadings and temperatures; these properties are used for the design of equipments. All these data are compiled in in-house thermodynamic routines that are further used for process evaluations as discussed in section 3.2.3.

3.2.2. Operational issues

From previous thermodynamic data, one can deduce that energy penalty will be significantly lowered with DMX-1 solvent compared to MEA. To go from the solvent to the process, one has to make sure that such good performances can actually be reached by ensuring that no operational issues will be encountered.

3.2.2.1. Liquid/liquid decantation

First of all, it was needed to check that liquid/liquid separation would not make any problem. To do so, experiments have been performed in a stirred cell and in a lab-scale decanter. In parallel to these tests, Euler/Euler CFD calculations have been performed for both types of tests. The first set of tests was used for adjusting different parameters depending on solvent properties including breakup/coalescence properties, while the second set of tests was used to validate the liquid/liquid decantation simulation approach, the CFD tool being further used for scaling-up purposes.

Concerning the first set of tests performed in a stirred cell, the DMX-1 solvent (loaded with CO₂) is stirred with an Ultra-Turrax homogenizer (2.5 cm diameter for a 6 cm diameter cell) at 11,000 rpm for approximately five minutes. Once the Ultra-Turrax is stopped, the liquid/liquid interfaces are followed in time. During those tests, the system is closed and heated at the desired temperature. For the operating conditions corresponding to pictures in Figure 2, the decantation of the different phases (gas released and two liquid phases formed) has occurred in less than one minute. One observes that the light phase is very limpid whereas the dense phase is opaque due to the presence of micro-droplets of the light phase. The opposite situation was to avoid; that is : heavy phase dispersed in the light phase. Indeed the heavy phase, which contains the CO₂, needs to be regenerated and should not be

dispersed in the light phase. Here, the light phase is clear and can indeed be directly sent back to the absorber without being regenerated, as expected.

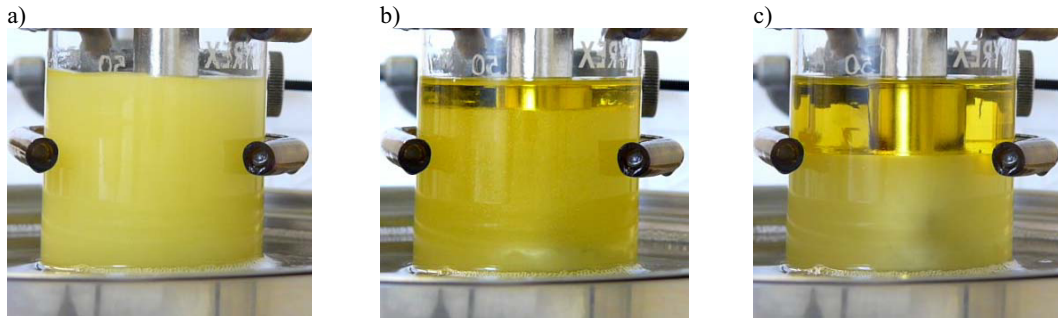

Figure 2 : Stirred-cell tests for the DMX-1 solvent : system at a) $t = 0$ s, b) $t = 15$ s and c) $t = 40$ s.

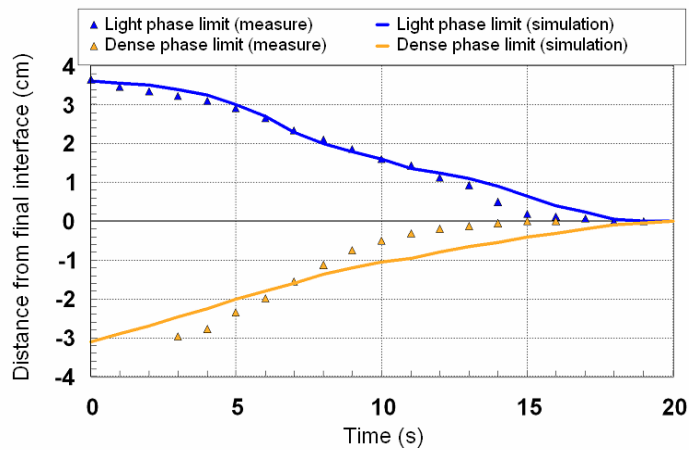

Figure 3 : CFD simulation of stirred cell tests, comparison between experimental and simulated profiles.

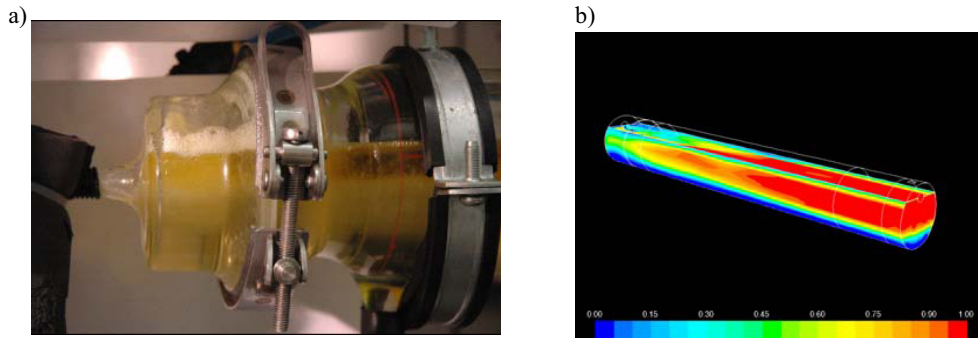

Figure 4: Tests with a laboratory scale decanter: application to the DMXTM solvent, CFD simulations of tests on DMXTM solvent in the laboratory scale decanter.

With such tests, decantation times and decantation fronts have been determined for several operating conditions. CFD calculations have been performed to reproduce such evolutions. The measured parameter is the distance

between the front of the superior and inferior interfaces and the final interface. Figure 3 shows the interfaces evolutions with time for operating conditions different from those corresponding to Figure 2, here two fronts can easily be determined. The light phase front is represented in blue, and the dense phase front in yellow. One observes from Figure 3 that, via the use of adapted in-house user-defined functions taking into account physical properties of the fluids and breakup/coalescence phenomena, CFD is able to reproduce experimental tests with a good accuracy even if a slight discrepancy is noticeable for the dense phase limit profile. To further validate the CFD tool, a comparison was made between tests performed in a laboratory decanter and simulations. The DMX-1 solvent is loaded with CO₂, pre-heated and sent in a decanter at a controlled temperature. The liquid flow rate set for this experiment is close to 20 kg/h. As can be seen from Figure 4.a, at decanter inlet, the solvent releases a fraction of the absorbed CO₂ and quickly separates into two liquid phases. Corresponding CFD simulations are shown in Figure 4.b. From volume fraction contours (red phase corresponds to the light phase, whereas the dense phase is represented in blue), it is also seen that the two phases indeed separate within a short length and that all decanter length is not required. The corresponding residence time is a few minutes only which make us confident for industrial designs.

3.2.2.2. Degradation

The stability of the solvent is an important property. Indeed, degradation of the solvent results in corrosion, foaming, unwanted emissions... In order to handle these problems, a reclaiming of the solvent can be done, or the inventory of solvent can be replaced, but these solutions have a huge impact on the operational costs. Definitely, the more stable a solvent is, the less operating problems are encountered. Unfortunately, it is very difficult to reproduce perfectly at laboratory scale degradation that occurs in an industrial plant. Therefore, we try to establish a rating of amines, from the more stable to the less stable for given conditions. Over a period of 15 days, in closed reactors maintained at 140°C with a high pressure of carbon dioxide (up to 20 bar) and/or oxygen (up to 4.2 bar), a very low degradation of DMX-1 has been observed. DMX-1 has less degradation than most molecules tested in these conditions [16-17], which are already drastic compared to usual plant operation conditions (up to 120°C, and up to 2 bar of total pressure). In addition, as regeneration of the solvent at a higher temperature could be a way to reduce the cost of PCC (a higher temperature at reboiler corresponds to a higher pressure which further induce a lower compression energy required for delivering high pressure carbon dioxide), we increased the duration of our tests and we increased the temperature of the reactors up to 180°C. Results in terms of percentage of degradation of the solvent over time are shown in Figure 5 where DMX-1 is compared to 40 wt.% MDEA. MDEA has been taken as a reference since it is already widely used in natural gas treatment without any known problem of degradation and because in similar tests it has been shown that it is the most stable amines among commercial ones [16-17]. Without CO₂ (open symbols), degradation rate of DMX-1 appeared to be seven times lower than the one of MDEA. The same trend is observed with an additional pressure of 20 bar of CO₂ (closed symbols). All these results make us confident to have a low degradation of DMX-1, even in the case of a regeneration at high temperature.

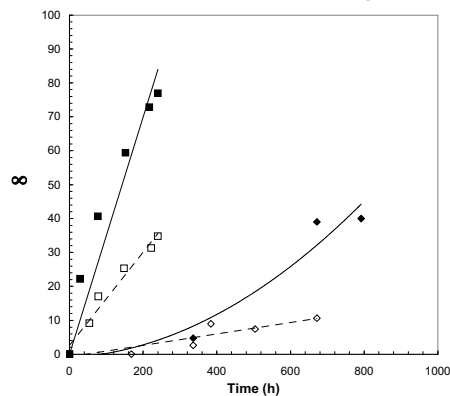

Figure 5 : Percentage of degradation of solvents in time at 180°C (square : MDEA; lozenge : DMX-1), with or without 20 bar CO₂ (respectively closed and open symbols).

3.2.2.3. Corrosion

In conventional MEA capture, corrosion represents a major operational issue [18-22]. It is well admitted that corrosivity of MEA is enhanced by high temperature and CO₂ loadings. Recent pilot plant experiments showed corrosion rates of carbon steel to reach more than 1 mm/year in the hot amine sections at the inlet or outlet of the stripper [17]. Therefore, designing or operating MEA units requires strong corrosion mitigation strategies, either by selecting corrosion resistant alloys, or by using corrosion inhibitors. For comparison, some corrosion tests were performed in the DMX-1 solvent. On the IFP Energies nouvelles pilot plant, corrosion rates of carbon steel coupons were found to be negligible (< 2 μm/year) at stripper inlet and at outlet (temperature ≈ 105°C). Other tests were performed in more severe conditions in autoclave, at 180°C and under 20bar CO₂. Even under these conditions, carbon steel gave excellent performance, with approximately 10 μm/year corrosion rate. Even if additional tests in more representative conditions are required (e.g. hydrodynamic and phase separation), all the corrosion results available to date indicate that the DMX-1 solvent is far less corrosive than MEA. Therefore, less costly construction materials should be employed, and the use of costly proprietary corrosion inhibitors should also be avoided.

3.3. Process evaluation

3.3.1. Process description

The DMXTM process is based on the particular property of demixing solvents to form two immiscible liquid phases for specific CO₂ loadings or temperature conditions, one having a particular high CO₂ loading. The possibility of easy separation of the two phases by decantation allows us to consider an important decrease of solvent mass flow at regeneration. Figure 6 shows a corresponding possible configuration for the process flow diagram. The DMXTM process mainly differs from the MEA process by having an additional operation unit of decantation. The decanter is preferably positioned after the amine/amine heat exchanger and before the regenerator. This unit operation exploits the liquid/liquid separation property of the solvent with the simultaneous effect of CO₂ charge and heat. Only the dense phase having a high CO₂ concentration is injected in the regenerator. The light phase is mixed with the regenerated solvent coming from the stripper and injected to the absorber.

3.3.2. Cost analysis of the DMX-1 process

Process simulations have been performed with SimSci PRO/II using IFP Energies nouvelles's proprietary thermodynamic model via user added subroutines, the design of the columns being made with an in-house simulator. Figure 6b presents the main characteristics of the DMX-1TM process used for the simulations. The main result, that is the energy consumption of the process is given. One observes, when comparing with 30 wt.% MEA, a significant change in energy consumption, the latter decreasing from 3.7 GJ/ton CO₂ down to 2.3 GJ/ton CO₂. With a particular process scheme, not shown here, this energy consumption can be as low as 2.1 GJ/ton CO₂. The first target, that is a significative reduction of the energy consumption at reboiler, is then reached.

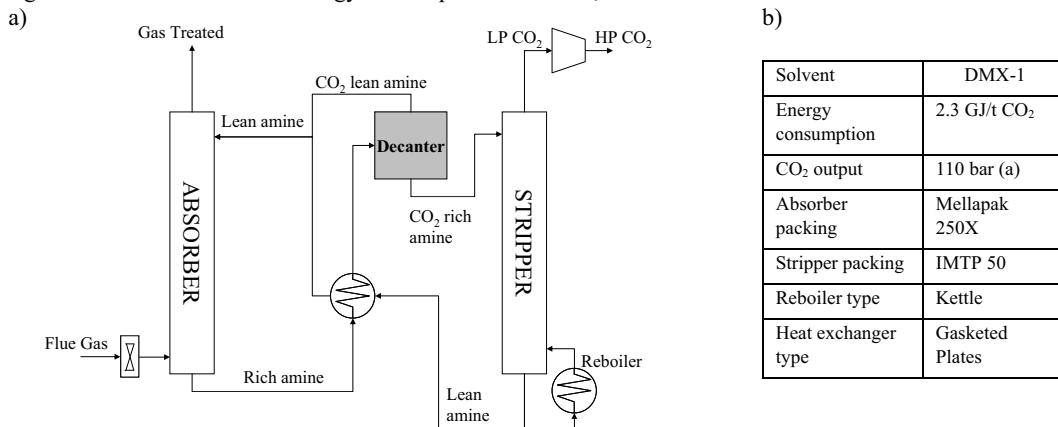

Figure 6 : a) Simplified process flow diagram of the IFP Energies nouvelles DMXTM process and b) corresponding main process characteristics.

As discussed in section 2, one should not restrict a process evaluation to energy consumption, both OPEX and CAPEX analysis for given boundary conditions have to be performed. In the present case, it appears that the CAPEX evaluation results in almost the same total CAPEX as obtained for the MEA 30wt.% process. The advantage of having a solvent with higher capacity, inducing smaller pumps and heat exchangers and an absorber diameter reduction, is counter balanced by the addition of the decanter and by the slight reduction of kinetics performances inducing higher absorber heights. The design of the decanter at industrial scale is made on the same residence time basis as the laboratory scale decanter which is known to be oversized (see Figure 4 and associated discussion). It is thus believed that the resulting cost estimation is conservative.

The technico-economic process evaluation of the DMX-1™ process finally results in a CO₂ cost of about 56 €/ton CO₂ which represents a significant reduction when comparing to the reference case estimated at about 75 €/ton CO₂ with same boundary conditions. From the cost analysis, further detailed elsewhere [7], it appears that there is no more one major item contrary to the MEA reference case, the main initial cost having been significantly reduced, but there are now five main items each representing around 20% of the total cost. This means that further optimization would be done only via intensive research considering all aspects, thermodynamic properties, kinetics, mass transfer properties, process optimization ... which is under work at IFP Energies nouvelles.

4. Conclusion

The present article describes the original DMX™ process developed by IFP Energies nouvelles and shows results concerning thermodynamic properties and operational issues. From thermodynamic studies and associated process simulations, it is shown that DMX-1™ enables important savings in terms of energy consumption, the energy at reboiler being decreased from 3.7 GJ/ton CO₂ (30wt.% MEA) down to 2.3GJ/ton CO₂ and even down to 2.1GJ/ton CO₂. It is also shown that common operational issues that could stop a development before industrial application have been studied and are in favor of this process. Next step consists in going from laboratory pilot plant currently under tests to large scale pilot validation.

5. References

- [1] Technology Roadmap – CCS , IEA Ed., see http://www.iea.org/papers/2009/CCS_Roadmap.pdf
- [2] Normand L, Lemaire E, Laborie G. paper presented at SOGAT 2010: March 28 - April 1: Abu Dhabi.
- [3] Ma'mum S, Svendsen HF, Hoff KA et al. Energy Conversion and Management 48 (2007) 251-258.
- [4] Puxty G, Rowland R, Allport A et al. Environ. Sci. Technol. 43 (2009) 6427-6433.
- [5] Knudsen J, Jensen JN, Vilhelmsen PJ et al. Energy Procedia, (1) 2009 783-790.
- [6] Abu-Zahra M, Schneiders LHJ, Niederer JPM et al. Int. J. of Greenhouse Gas Control 1 (2007) 37-46.
- [7] Raynal L, Bouillon PA, Gomez A et al. submitted to Chem. Eng. J.
- [8] Carrette P-L, Cadours R, Boucot P et al. 10th meeting of the IEA International Post-Combustion CO₂ Capture Network, 24-25th May 2007, Lyon, France.
- [9] Lemaire E, Raynal L. 12th meeting of the IEA International Post-Combustion CO₂ Capture Network, 28th-1st October, 2009, Regina, Canada.
- [10] Horstmann S, Mougin P, Lecomte F et al. J. Chem. Eng. Data, 2002, 47 (6), pp 1496–1501.
- [11] Awana J, Valtz A, Coquelet C, et al. Chem. Eng. Research and Design, 2008, 86(6), 600-605
- [12] Lee J, Otto F, Mather A. Can. J. Chem. Eng., 1974, 52, 803-805.
- [13] Lee J, Otto F, Mather A. J. appl. Chem. Biotechnol., 1976, 26, 541-549.
- [14] Blanchon Le Bouhelec E, Mougin P, Barreau A, et al. Energy & Fuels, 2007, 21, 2044-2055.
- [15] Aleixo M, Prigent M, Gibert A, Porcheron F, Jacquin M. presentation at GHGT-10 - submitted to Energy Procedia.
- [16] Lepaumier H, Picq D, Carrette P.-L. Ind. Eng. Chem. Res. 2009, 48, 9061.
- [17] Lepaumier H, Picq D, Carrette P.-L. Ind. Eng. Chem. Res. 2009, 48, 9068.
- [18] Kittel J, Idem R, Gelowitz D et al. Energy Procedia, 2009, 1, 791.
- [19] Kittel J, Fleury E, Vuillemin B et al. Eurocorr 2010, Moscow, 2010
- [20] Nielsen RB, Lewis KR, McCullough JG et al. Proceedings of the Laurance Reid Gas Conditioning Conference, 1995, 1995
- [21] Soosairakasam IR, Veawab A. International Journal of Greenhouse Gas Control, 2008, 2, 553.
- [22] Veawab A, Tontiwachwuthikul P, Chakma A. Industrial & Engineering Chemistry Research, 1999, 38, 3917.