



HAL
open science

Substitution of Carbon Steels for ASME SA-533 Type E for Lightweight Equipment

Valery Ngomo, François Grosjean, Olav Tangen, Xavier Courtial

► **To cite this version:**

Valery Ngomo, François Grosjean, Olav Tangen, Xavier Courtial. Substitution of Carbon Steels for ASME SA-533 Type E for Lightweight Equipment. Corrosion 2019, NACE, Mar 2019, Nashville, United States. hal-02462549

HAL Id: hal-02462549

<https://ifp.hal.science/hal-02462549>

Submitted on 31 Jan 2020

HAL is a multi-disciplinary open access archive for the deposit and dissemination of scientific research documents, whether they are published or not. The documents may come from teaching and research institutions in France or abroad, or from public or private research centers.

L'archive ouverte pluridisciplinaire **HAL**, est destinée au dépôt et à la diffusion de documents scientifiques de niveau recherche, publiés ou non, émanant des établissements d'enseignement et de recherche français ou étrangers, des laboratoires publics ou privés.

Substitution of Carbon Steels for ASME SA-533 Type E for Lightweight Equipment

Valery Ngomo
Industeel ArcelorMittal
118 route des Etaings
Rive de Gier, 42800
France

Olav Tangen
Midsund Bruk NOV Group
Industriveien 50
Midsund, 6475
Norway

François Grosjean
IFP Energies nouvelles
Rond-point de l'échangeur de Solaize
Solaize, 69360
France

Xavier Courtial
Prosernat Axens Group
89 boulevard Franklin Roosevelt
Rueil-Malmaison, 92500
France

ABSTRACT

The use of MnMo(Ni) alloys ASME SA-533 type B or type C in lieu of carbon manganese steels (SA-516 Grade 65 or Grade 70) started about 30 years ago to produce lightweight pressure vessels. But the development of these low alloy steels for the fabrication of equipment for wet H₂S service ("sour service") remains limited due to their weldability considered as challenging. This paper aims at introducing newly developed material ASME SA-533 type E class 2, and provides results obtained in base metal and welded joints, especially with respect to NACE standard MR0175 / ISO 15156-2. Finally, a case study on an absorber for amine gas treating units (AGRU) will be described to illustrate the mass savings that can be achieved with SA-533 type E class 2.

Key words: lightweight equipment, low alloy steel, wet H₂S service, welding, SA-533 type E

INTRODUCTION

Weight reduction of more and more complex oil and gas production facilities has gained importance, especially for FPSO or FLNG units. For this purpose, low alloy high strength steels (ASME SA-533 type B or type C, class 2) started being used about 30 years in North Sea projects instead of carbon manganese steels, to save weight by reduction of vessel wall thickness. But weldability of such high strength steels remains challenging, especially for equipment dedicated to sour service that must comply with NACE MR0175 / ISO 15156-2 requirements.

To overcome this issue, we have developed SuperElso® 533 E based on ASME SA-533 type E material. It is a high strength steel with lean chemistry delivered in quenched and tempered condition, that combines high tensile properties with good Charpy-V notch toughness at low testing temperatures, and exhibits resistance to hydrogen-induced cracking (HIC) as good as the one achieved with carbon

manganese steels. Weldability of this material has been studied with the support of MIDSUND BRUK who carried out welding trials using submerged arc welding (SAW) process. Testing conditions and results will be provided, that show especially that the material meets NACE MR0175 / ISO 15156-2 requirements for hardness in heat affected zone (HAZ) thanks to fine-tuned welding parameters, including post weld heat treatment (PWHT).

Finally, the paper describes a case study by Prosernat and IFP Energies Nouvelles of a 4.5-m (14.76-ft) diameter amine absorber for AGRU showing how mass gain can be obtained by substitution of SA-516 Grade 65 for SA-533 type E class 2.

Requirements for H₂S-containing environment

The standard ISO 15156 [1] (equivalent to NACE MR0175) provides important requirements and recommendations for the selection and qualification of carbon and low alloy steels for service in equipment used in oil and natural gas production and natural gas treatment plants in H₂S-containing environments.

The standard ISO 15156 Part 2 lists requirements that must be met by carbon and low alloy steels to be considered as SSC-resistant. Among these requirements, there is the maximum acceptable hardness value of welds measured in Vickers HV 10 (250 HV). In addition, for low alloy steels a minimum PWHT temperature of 620°C (1150 °F) shall be used.

EXPERIMENTAL PROCEDURE

Test plate

Material used for purpose of characterization was taken from a 120-mm (4.72”) thick plate produced as per ASME SA-533 type E class 2:

- Austenitizing at 925°C (1697 °F), water quenching
- Tempering at 625°C (1157 °F) for 3.42 hours.

Table 1 exhibits heat analysis and sample analysis (quarter-thickness) in comparison with ASME requirement for SA-533 type E material. Compared to ASME requirement on chemistry, the tested material was subject to following metallurgical adjustments:

- Low Carbon content to ensure good weldability;
- Balanced alloying of Mo and Cr to guarantee strength properties;
- Ni addition for hardenability and impact toughness. Ni content is below 1% as per ISO 15156-2;
- No microalloying (V, Ti, etc.) to ease HAZ softening;
- Very low levels of tramp elements (S, P); S and P contents are much lower than what is specified in ASTM A533 because these elements are detrimental to resistance to hydrogen-induced cracking (HIC) and impact toughness properties.

Table 1: Chemical composition of the tested material in mass wt. % (balance Fe)

		C	Mn	P	S	Si	Mo	Ni	Cr	Ti	V
ASME SA-533 type E	Heat	≤0.20	1.15-1.70	≤0.020	≤0.015	0.15-0.40	0.25-0.60	0.65-1.00	≤0.60	≤0.030	≤0.030
	Product	≤0.20	1.04-1.84	≤0.020	≤0.015	0.13-0.45	0.21-0.64	0.57-1.03	≤0.64	≤0.040	≤0.040
Test plate	Heat no.22407	0.10	1.26	0.006	0.001	0.16	0.50	0.88	0.52	0.002	0.005
	Product	0.11	1.25	0.006	0.002	0.15	0.49	0.91	0.53	0.002	0.005

Following tests were carried out on tested material in quenched and tempered condition:

- Charpy V-notch impact toughness tests at quarter- and mid-thickness according to NF EN ISO 148-1 [2];
- Tensile tests at room temperature (quarter- and mid-thickness) according to ASME SA 370 [3];

In addition, evaluation of tested material for resistance to hydrogen-induced cracking tests was done in accordance with NACE TM-0284 solution A [4], in simulated PWHT condition.

Weldability study

Welding test was performed on 120-mm thick coupon using submerged arc welding process (SAW, see Figure 1). A butt weld X-groove joint was done, with a multipass sequence (see Figure 2). Welding parameters and post weld heat treatment were selected considering thickness, ASME Boiler and Pressure Vessel Code (BPVC) and fabricator's experience. Welding consumable and welding parameters are provided in Table 2 and Table 3, respectively.

Following welding, post weld heat treatments were done on welded coupons before characterization. PWHT conditions are provided in Table 4. SA-533 type E class 2 is P-number 3 Group 3 material per ASME section VIII division 2 classification. Hence PWHT is mandatory for equipment made of this material, and the minimum PWHT temperature shall be 595°C (1103 °F). We applied a PWHT temperature of 625°C (1157 °F) to be also in accordance with ISO 15156-2 requirement for low alloy steel to be used in sour service.

Following tests were done on welded coupons (base metal, heat affected zone and weld metal):

- Mechanical testing;
- CVN impact test toughness;
- Hardness survey.



Figure 1: SAW process (121) being done on coupon in SA-533 type E material

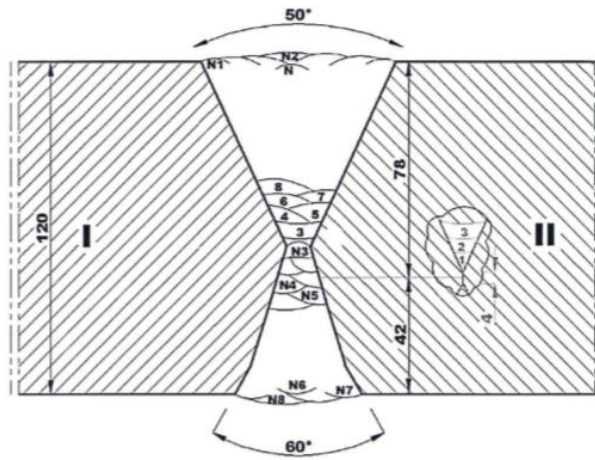

Figure 2: Butt weld X-groove and welding sequence

Table 2: Welding consumables used for the welding test

Filler metal (wire/flux combination)		
Brand name	Type	Classification
OE SD3Ni1 0.5Mo	Wire 4mm	AWS/ASME SFA5.23:EG/EF3
OP 121TT	Flux	

Table 3: Welding parameters

Pass no.	Diameter (mm)	Welding process	Current (A)	Voltage (V)	Current / Polarity	Welding speed (mm/min)	Heat input (kJ/mm)
1	4.00	121	450-500	24.0-26.0	DC+	500-530	1.2-1.6
2-7	4.00	121	560-630	25.0-27.0	DC+	520-560	1.5-2.0
8-N	4.00	121	680-700	31.0-33.0	DC+	1030-1080	1.2-1.3
8-N	4.00	121	600-610	32.0-34.0	AC	1030-1080	1.1-1.2
N1-N2	4.00	121	610-620	27.0-29.0	DC+	530-550	1.8-2.0
N3-N4	4.00	121	610-620	27.0-29.0	DC+	530-550	1.8-2.0
N5-N6	4.00	121	680-700	31.0-33.0	DC+	1030-1080	1.2-1.3
N5-N6	4.00	121	600-610	32.0-34.0	AC	1030-1080	1.1-1.2
N7-N8	4.00	121	610-620	27.0-29.0	DC+	530-550	1.8-2.0

Table 4: post weld heat treatments applied on welded coupons

Coupon dimensions	Thickness	PWHT temperature	PWHT soaking time
500mm x 1000mm (19.68" x 39.37")	120mm (4.72")	625°C (1157 °F)	5 hrs.
500mm x 1000mm (19.68" x 39.37")	120mm (4.72")	625°C (1157 °F)	15 hrs.

RESULTS

Characterization of test plate

Mechanical properties

Tensile requirements for SA-533 type E class 2 are indicated in Table 5. Tensile tests were done according to ASME SA-370, at room temperature in transverse orientation. According to results (Table 5, Figure 3, Figure 4), yield strength and ultimate tensile strength of the tested material in quenched and tempered condition conform to the requirements shown in Table 5, both at quarter- and mid-thickness.

Table 5: Tensile requirements and test results at room temperature

SA-533 type E class 2	Yield strength MPa (ksi)	Tensile strength MPa (ksi)	Elongation %
Required	≥ 485 (70)	620-795 (90-115)	≥ 18
Results, quarter-thickness	605 (87.7)	692 (100.4)	25
Results, mid-thickness	586 (85.0)	685 (99.3)	23

Charpy-V notch impact toughness

Table 3.13 of ASME BPVC, section VIII, Division 2 (edition 2015) provides CVN impact test requirements for carbon and low alloy steels as a function of the minimum specified yield strength (SMYS) for various thicknesses.

Considering the SMYS of tested material (485 MPa) and sample thickness, the CVN impact test requirement was estimated at 68 J (50 ft-lbs). CVN impact tests were done at -40°C (-40 °F) and -60°C (-76 °F) in transverse orientation. According to results shown in Figure 5, toughness properties of tested material in quenched and tempered condition met ASME table 3.13 requirements, whatever the test temperature. Impact toughness values measured at quarter-thickness were slightly higher than values at mid-thickness.

Evaluation of resistance to hydrogen-induced cracking

Sampling for the evaluation of the resistance of tested material to hydrogen-induced cracking was done as stipulated by NACE TM 0284 (edition 2011). Test conditions are provided in Table 6. Prior to the HIC testing, tested material was subjected to simulated PWHT (SPWHT) at 625°C for 5 hours. HIC tests were performed in SPWHT condition as it is representative of the service condition of the equipment.

According to test results shown in Table 7, the tested material was found to be resistant to hydrogen-induced cracking.

Table 6: Test conditions for evaluation of SA-533 type E class 2 for resistance to HIC

Test solution	Initial pH	pH at the start of test	pH at the end of test	Test temperature
Solution A	2.7	3.1	3.8	25°C (77 °F)

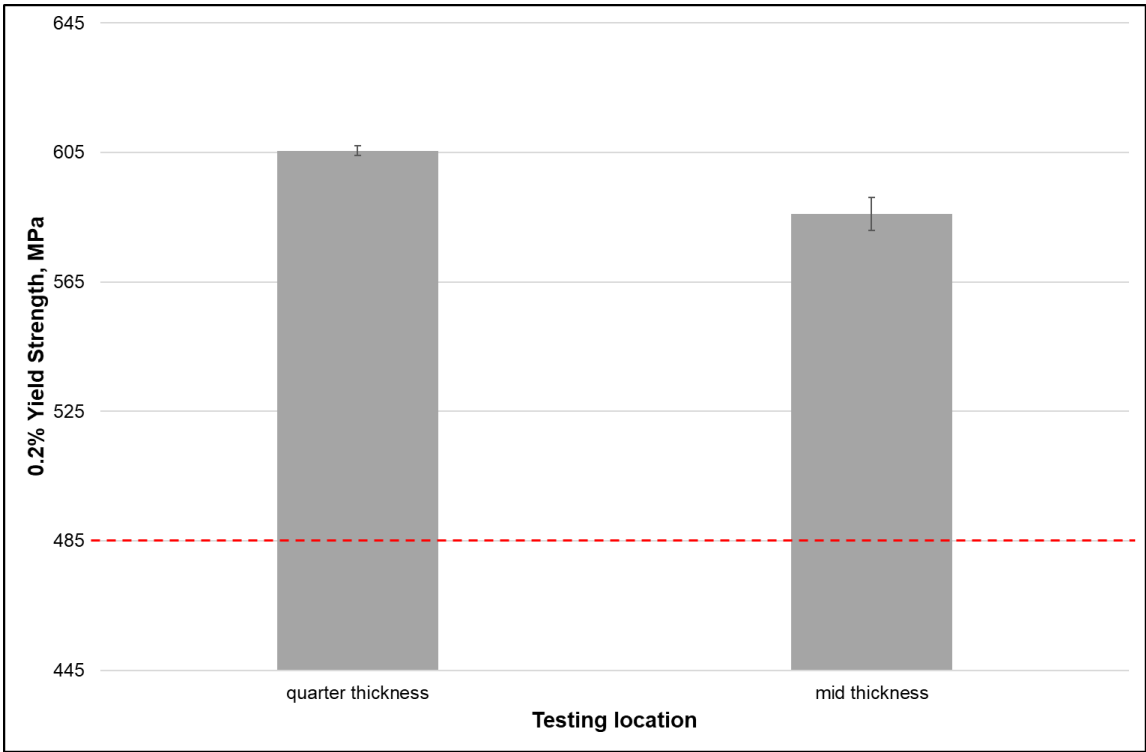

Figure 3: Yield strength at room temperature

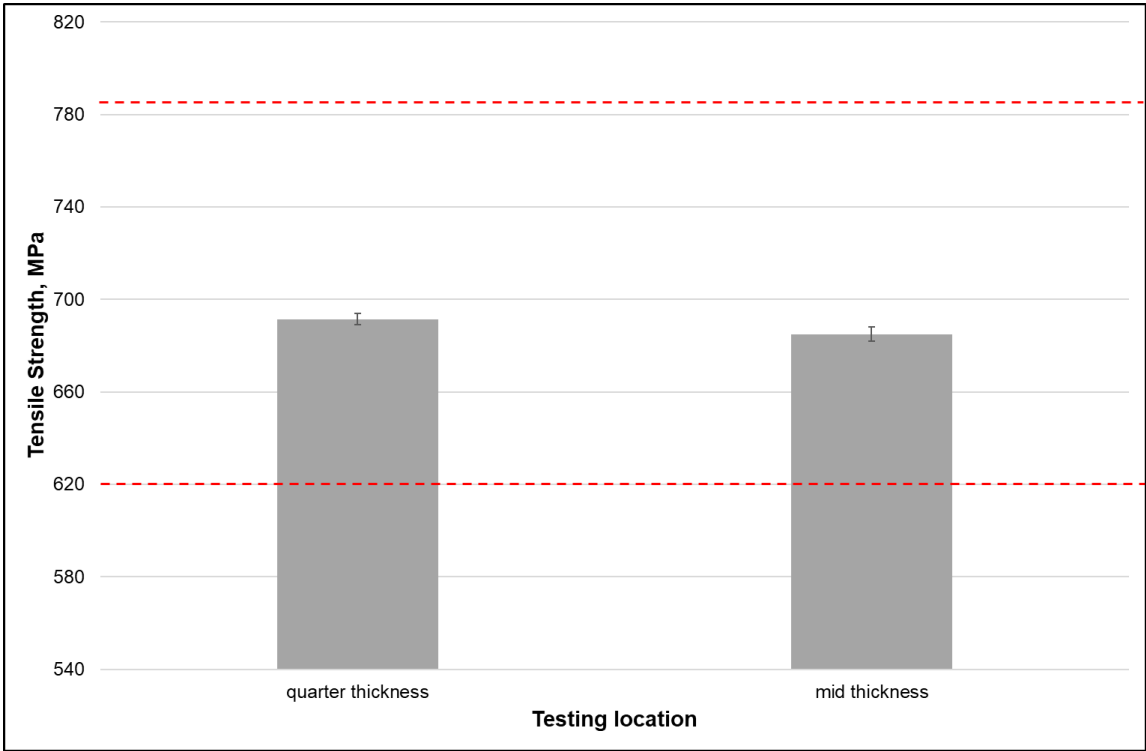

Figure 4: Ultimate tensile strength at room temperature

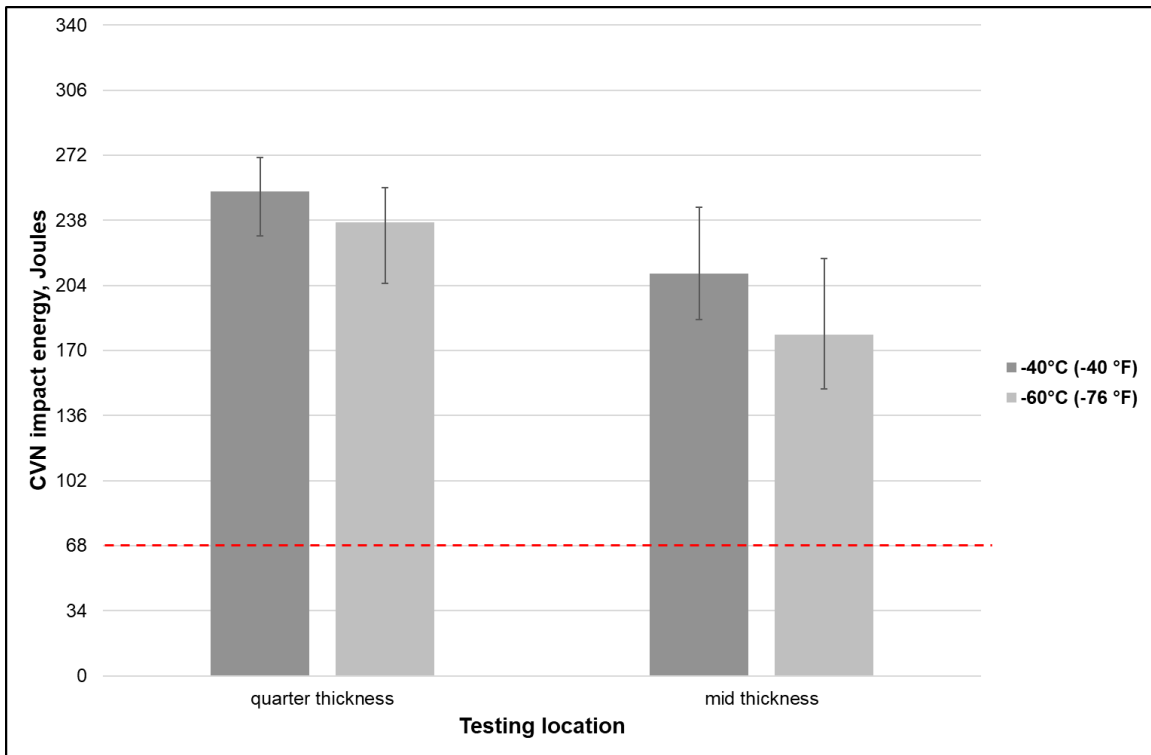

Figure 5: CVN impact toughness at -40°C and -60°C

Table 7: Cracking evaluation (crack length ratio CLR, crack thickness ratio CTR and crack sensitivity ratio CSR)

Specimen no.	Values	CLR %			CTR %			CSR %		
32107	Individual	0	0	0	0	0	0	0	0	0
	Average	0			0			0		
32108	Individual	0	0	0	0	0	0	0	0	0
	Average	0			0			0		
32109	Individual	0	0	0	0	0	0	0	0	0
	Average	0			0			0		
32110	Individual	0	0	0	0	0	0	0	0	0
	Average	0			0			0		
32111	Individual	0	0	0	0	0	0	0	0	0
	Average	0			0			0		

Characterization of welded joints

This section provides results of characterization done on welded coupons that were subjected to post weld heat treatments of 625°C – 5 hrs. and 625°C – 15 hrs., respectively.

Macrographic examination and hardness survey

Macrographs were performed on a full-thickness weld cross section for each PWHT with a typical preparation as following:

- Grinding;
- Automatic polishing with diamond paste solution (9 microns to 1 micron),
- Etching with Nital 3% etchant (immersion with agitation during 20 sec.),
- Observation with binocular microscope and optical microscope.

Vickers hardness (HV10) tests have been realized on two cross sections following ISO 9015-1:201. Figure 6 shows the macrograph of weld cross section for PWHT of 625°C-5hrs. with hardness test locations.

Table 8 provides maxima of hardness values measured at base metal (BM), heat affected zone (HAZ), coarse grain HAZ (CG HAZ) and weld metal (WM). According to those results, weld coupons meet hardness requirements of ISO 15156-2, table A1. However, one can highlight that values measured in CG HAZ were found on the borderline of ISO 15156-2 requirement, for PWHT done at 625°C – 5hrs.

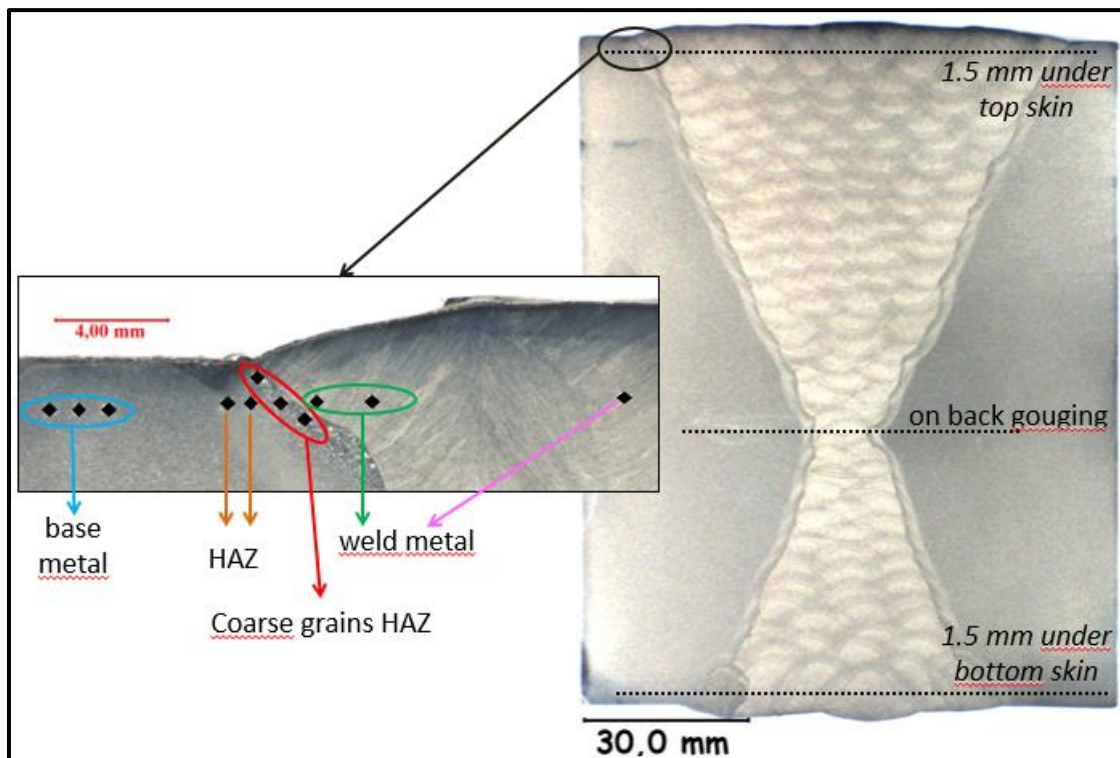

Figure 6: Weld cross section macrograph (PWHT 625°C – 5hrs.)

Table 8: Vickers hardness survey (maxima) on welded joints following PWHT

		Hardness HV10 – max value			
PWHT	Location	Base metal (BM)	HAZ	CG HAZ	Weld metal
625°C – 5 hrs.	1.5mm under top skin	220	235	249	214
	On back gouging	212	225	249	226
	1.5mm under bottom skin	229	239	250	234
625°C – 15 hrs.	1.5mm under top skin	216	225	238	205
	On back gouging	209	221	242	215
	1.5mm under bottom skin	224	234	242	227
ISO 15156-2 / NACE MR0175 (table A.1)		Maximum acceptable hardness is 250 HV			

Tensile properties

Following sampling was done for tensile testing:

- Base metal quarter-thickness (10-mm diameter round tension specimen);
- Transverse joint quarter-thickness (10-mm diameter round tension specimen);
- Weld metal as per ISO 5178:2001 [5] (small size 5-mm diameter round tension specimen).

For each sampling, a set of two specimens was used. Figure 7 and Figure 8 show results (average values) for yield strength and ultimate tensile strength, respectively. Only values measured in PWHT condition of 625°C – 15hrs are provided as it is the most severe condition for strength.

Following highlights can be made on tensile test results following PWHT of 625°C – 15 hrs.:

- Yield strength properties conform to ASME requirements for SA-533 type E class 2 (485 MPa minimum);
- With respect to ultimate tensile strength, values in base metal and transverse joint conform to ASME requirements (620 – 795 MPa), while tests results in weld metal are below the minimum required value.

UTS properties in the tested weld consumable with PWHT condition of 625°C-15hrs confirm results achieved in another study with the same consumable brand S3NiMo1 [6], that is to say that tensile properties in weld metal may be close to or below the minimum required after PWHT 625°C-15hrs (equivalent to PWHT 635°C-8h30min).

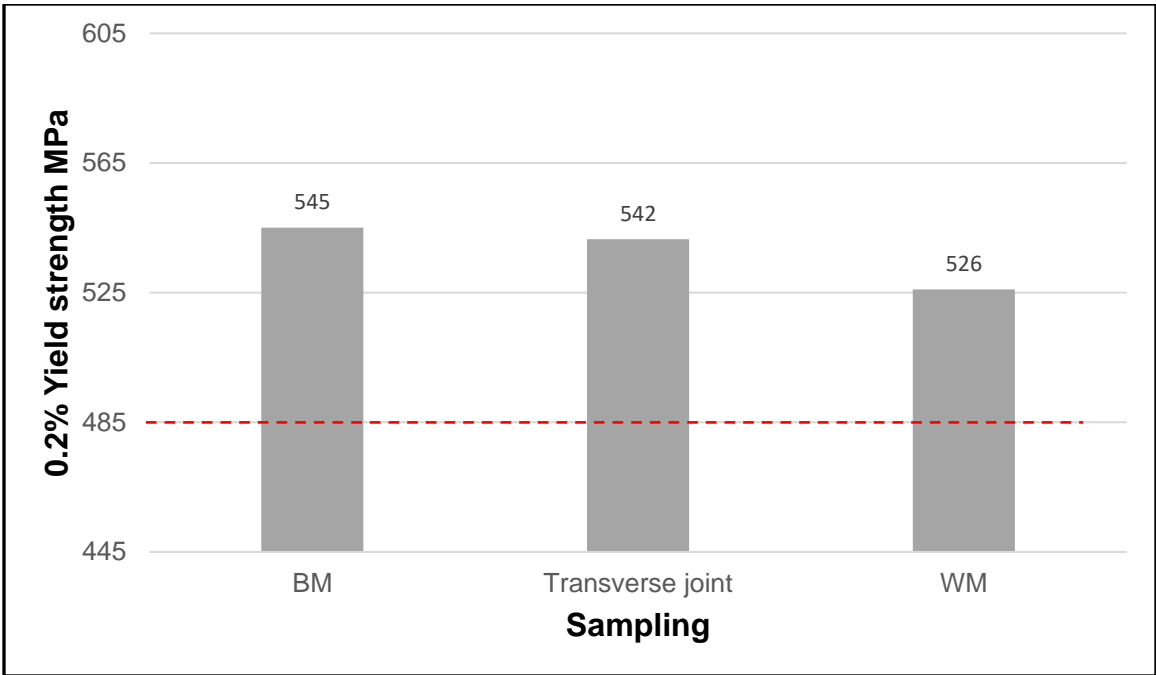

Figure 7: Yield strength properties in welded joint following PWHT 625°C – 15hrs.

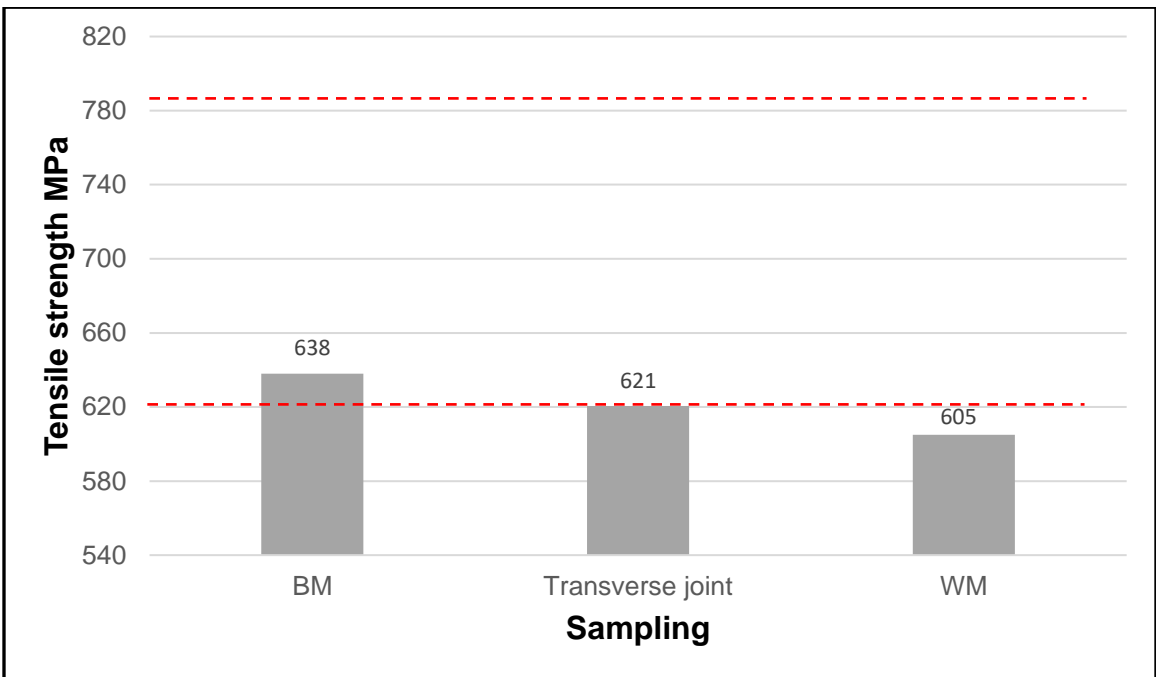

Figure 8: Ultimate tensile strength properties in welded joint following PWHT 625°C – 15hrs.

Charpy-V notch impact toughness

Toughness specimens were machined at quarter- and mid-thickness in base metal, weld metal and transverse weld joint, respectively. For transverse welding specimens, an etching (with Nital 5% etchant) was performed to determine the exact position of notch: 2 mm to fusion line.

CVN tests were carried out at test temperature of -50°C (-58 °F). This test temperature was selected in agreement with pressure vessel fabricators involved in projects with low minimum design metal temperatures (MDMT). Following highlights can be made from test results (Figure 9, Figure 10):

- whatever the test location and PWHT condition, CVN impact properties conform to requirements. Values are above 100 Joules at -50°C in base metal and HAZ, both in quarter- and mid-thickness;
- there is a decrease in CVN impact toughness for high PWHT condition (625°C-15hrs.), especially in weld metal (mid-thickness).

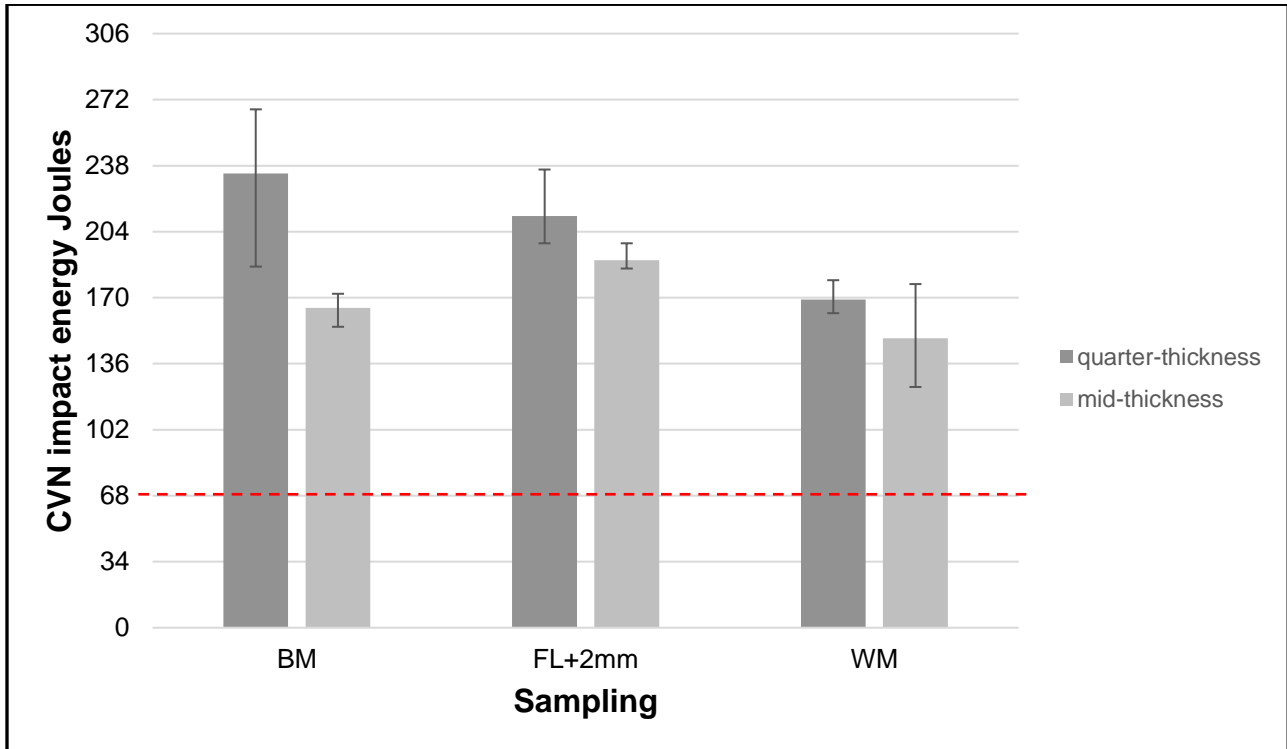

Figure 9: CVN impact toughness in welded joint at -50°C (PWHT 625°C-5hrs.)

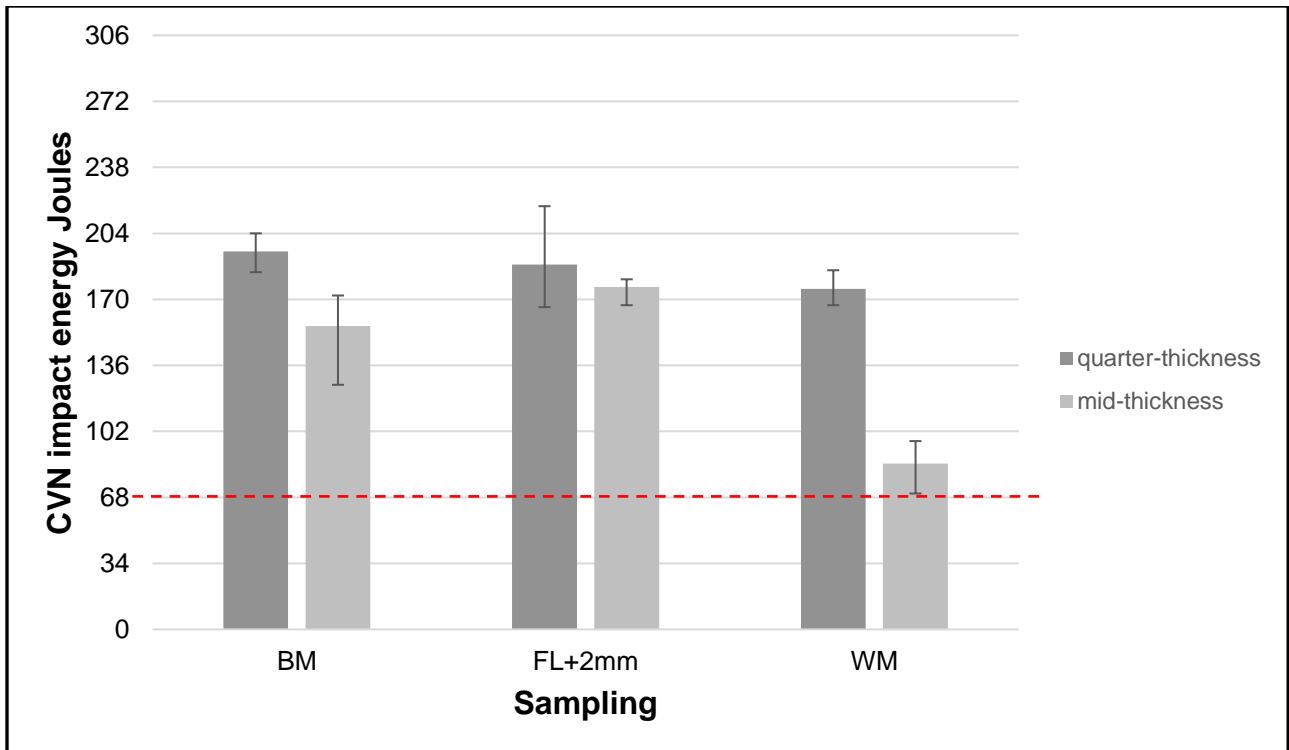

Figure 10: CVN impact toughness in welded joint at -50°C (PWHT 625°C-15hrs.)

CASE STUDY: AMINE ABSORBER

Design considerations

Carbon-manganese steel ASME SA-516 Grade 65 (HIC-resistant quality) is the benchmark solution for the fabrication of absorbers in amine treating units. Due to the high pressure in the absorber, it may be of interest to consider the use of higher strength materials such as SA-533 type E class 2 for wall thickness (weight) reduction.

Allowable stresses for materials SA-516 Grade 65 and SA-533 type E class 2 for vessels designed according ASME Section VIII, Division 2 Class 2 can be found in Tables 5A of ASME Section II, Part D. A comparison of allowable stresses for both materials is shown on Figure 11.

The required thickness of a cylindrical shell due to internal pressure for ASME Section II, Division 2 Class 2 is shown in Eq. (1)

$$t = \frac{D}{2} \times \left(\exp \left[\frac{P}{S \times E} \right] - 1 \right) \quad (1)$$

Where:

t	Required thickness of the shell
D	Internal diameter
P	Internal pressure
S	Allowable stress of material
E	Joint efficiency factor

Table 9 shows the shell thicknesses for a vessel constructed in either material, with following assumptions:

- Internal pressure: 75 bar (1087 psi);
- Internal diameter: 4700 mm
- A joint efficiency factor of 1.

As shown in Table 9 and plotted in Figure 12, there is a significant potential for thickness reduction by switching from carbon steel SA-516 Grade 65 to low alloy steel SA-533 type E class 2.

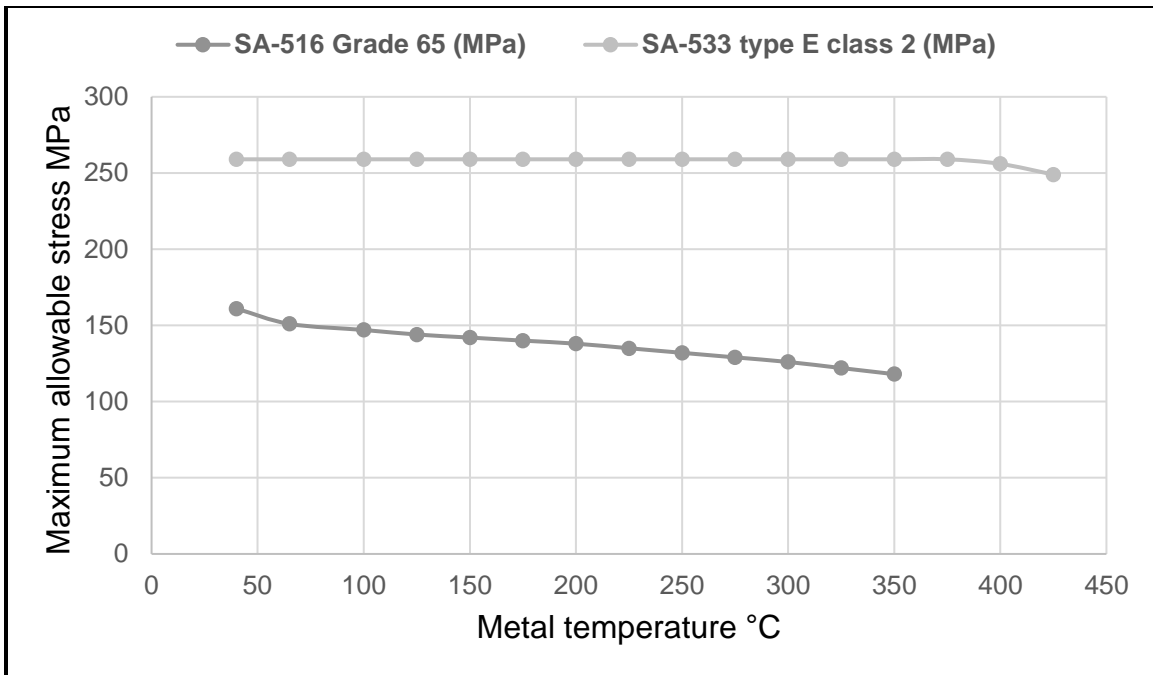

Figure 11: Allowable stresses for materials SA-516 Grade 65 and SA-533 type E class 2

Table 9: Estimation of shell thickness depending on temperature (design rules of ASME Section II, Division 2, Class 2)

Temperature °C	100	150	200	250	300	325	350
SA-516 Gr.65	123	127	131	137	144	149	154
SA-533 type E cl.2	69	69	69	69	69	69	69

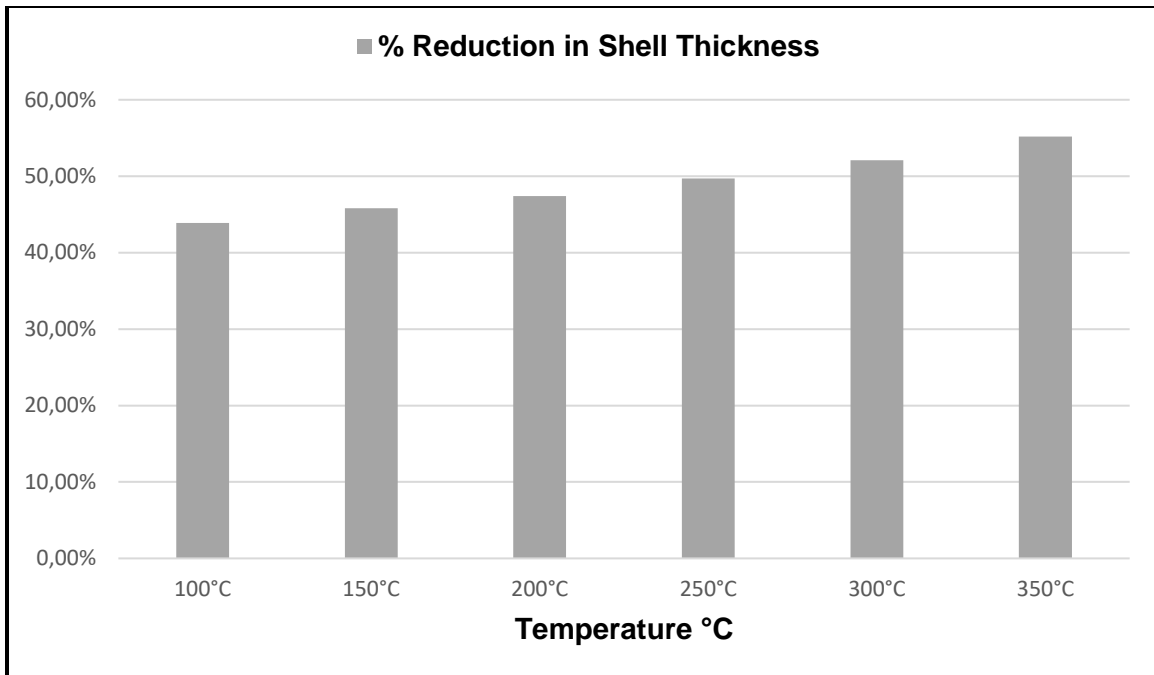

Figure 12: Percentage Reduction by substitution of SA-516 Grade 65 for SA-533 type E class 2 (75 bar)

Absorber in sour service

Some corrosion (weight loss) and cracking (U-bend and four-point bend) tests in conditions representative of an AGRU absorber in sour gas conditions have shown that SA-533 type E class 2 has similar corrosion and cracking resistance as the benchmark solution SA-516 Grade 65 [7]. The reference paper provides full details on the experimental conditions and test results.

Baseline scenario

The case investigated by the study is an existing unit built in the Middle East. It is a matter of checking the benefits of using high strength low alloy steel, in the context of future projects. The approach consists in calculating the weight of the two columns of the AGRU with the alternate materials and comparing them with the steel grades originally selected in the built unit.

The amine unit processes 380 MMSCFD of gas at 67 bara. The feed gas contains 3.5% H₂S and 5% CO₂ and the solvent flow, consisting of MDEA 45%wt, is 750 Sm³/hr. Unit and absorber main design parameters are provided in Table 10 and Table 11, respectively.

Table 10: Main design parameters of the amine gas treating unit

Gas flowrate	MMSCFD	380
Operating pressure	bar	66
Operating Temperature	°C	91
H ₂ S content	% mol	4.80
CO ₂ content	% mol	5.60

Table 11: Design parameters for the amine absorber

	Absorber
Dimensions D x T/T	4.7 m x 25.8 m
Design code	ASME VIII div2
Design pressure	75 bar
Design Temperature	115°C
Material	SA-516 Gr 65 + clad for top section
Shell thickness	127 mm
Gross weight (total)	454 tonnes

Results

Based on material allowable stresses and design parameters, we have calculated the thickness and weight reduction provided by SA-533 type E class 2. Results are shown in Table 12. The use of the low alloy steel allows a mass gain with an order of magnitude of 35%, bound to the lesser thickness permitted by the high mechanical properties of this grade.

Table 12: Estimation of mass reduction for an absorber in amine gas treating unit

	Shell thickness	Weight
Reference case: SA-516 Grade 65	125 mm	365 tons
Alternative : SA-533 type E class 2	80 mm	234 tons
Percent reduction	35%	35 %

CONCLUSIONS

Use of SA-533 type E class 2 in sour service conditions

The increasing complexity of some oil and gas installations and the need for weight reduction have led to the use high strength low alloy steels for replacement of the baseline carbon steel solution. The remaining challenge consists in their use for sour service, as they must both meet requirements for sour service (low HAZ hardness) and guarantee high strength.

The characterization of the newly developed material ASME SA-533 type E class 2 has shown that the parent material combines high strength properties with very good CVN impact toughness (> 100 Joules at -50°C). The evaluation of this material for resistance to hydrogen-induced cracking (NACE TM0284, solution A) has shown a performance identical to HIC-resistant carbon steel A-516 (Grade 65 or Grade 70).

Following highlights can be made from the weldability study carried out by a fabricator:

- Fine-tuned welding parameters and PWHT are required to meet NACE MR0175 / ISO 15156-2 requirements for HAZ hardness (maximum 250 HV in base metal, HAZ and weld metal);
- High CVN impact toughness values can be guaranteed, included in weld metal down to -50°C;
- Some hardness measurements are close to NACE limit of 250 HV10 for the lower PWHT condition (625°C during 5hrs.), which supports the challenge posed by high strength steels.

Benefits of SA-533 type E class 2 for lightweight equipment

Thanks to much higher allowable stresses than carbon steel grades, SA-533 type E class 2 provides a significant reduction of vessel wall thickness, and therefore weight reduction. Considering ASME design rules (section VIII, Division 2, Class 2) one can expect up to about 50% reduction in wall thickness depending on vessel and design parameters.

The case study done on a 4.7-m diameter amine absorber shows that the low alloy steel has same corrosion and cracking resistance in amine service as baseline option SA-516 Grade 65, while providing 35% reduction in wall thickness (125 mm for carbon steel versus 80 mm for low alloy steel).

In summary, high strength low alloy steels could be used in sour service provided that a balanced chemistry is defined and optimized welding parameters (consumables, conditions, PWHT) are tuned. The authors concede that current results obtained on SA-533 type E class 2 with submerged arc welding (SAW) process must be optimized before considering the tested material as a substitution for carbon steels SA-516 Grade 65 or Grade 70 in sour service.

REFERENCES

1. ISO 15156 (latest revision), "Petroleum and natural gas industries – Materials for use in H₂S-containing environments in oil and gas production" (Geneva, Switzerland: ISO).
2. NF EN ISO 148-1 (latest revision), "Metallic materials – Charpy pendulum impact test – Part 1: Test method" (La Plaine Saint-Denis, France: AFNOR).
3. ASME SA-370 (latest revision), "Test Methods and Definitions for Mechanical Testing of Steel Products" (New York, NY: The American Society of Mechanical Engineers).
4. NACE Standard TM-0284 (edition 2011), "Evaluation of Pipeline and Pressure Vessel Steels for Resistance to Hydrogen-induced Cracking" (Houston, TX: NACE International).
5. ISO 5178:2001, "Destructive tests on welds in metallic materials – Longitudinal tensile test on weld metal in fusion welded joints" (Geneva, Switzerland: ISO).
6. I. Lancini et al., "Development of New High Strength Steel SuperElso® 533E for Sour Service", European Symposium on Pressure Equipment (Paris, France: AFIAP, 2016).
7. G. Perdu *et al.*, "Alternative metallurgies reduce the cost of amine gas treating units", GPA Midstream Convention (Austin, TX: GPA Midstream Association, 2018)